

Product Overview

NSPGD1 series are calibrated gauge pressure sensor which combines state-of-art MEMS sensor technology and CMOS mix-signal processing technology to produce an amplified, fully conditioned, multi-order pressure and temperature compensated sensor in a Double In-line Package (DIP) with tube port. NSPGD1 series pressure sensor is target for household electric appliances and the small kitchen and bathroom home-appliances. Combining the pressure sensor with a signal conditioning ASIC in a single package simplifies the use of advanced silicon micromachined pressure sensors. The pressure sensor can be mounted directly to a standard printed circuit board and an amplified, high-level, calibrated pressure signal can be acquired from the digital interface or analog/frequency output. This eliminates the need for additional circuitry, such as a compensation network or micro-controller containing a custom correction algorithm. NSPGD1 series are designed for operating pressure ranges of -10kPa ~ 10kPa Gauge, very suitable for household electronics such as washing machine and dishwasher.

Key Features

- Custom range -10kPa~10kPa
- Temperature range 0~70°C
- Operating voltage 3V~5.5V
- 12bit Analog output
- 24bit I²C output
- Frequency output
- High accuracy
 - Total error band initially better than ±1%
 - Full life accuracy better than ±2.5%
- Front side of the chip enters the gas , not easing to block
- Waterproof and moisture-proof treatment inside

Applications

- Washing machine
- Dishwasher, water purifier
- Air bed, massage chair
- Smart sphygmomanometer, oxygen generator
- Industrial control
- IoT pressure detection

Device Information

Part Number	Package	Body Size
NSPGD1	DIP8	10.4mm*10.4mm

Outline

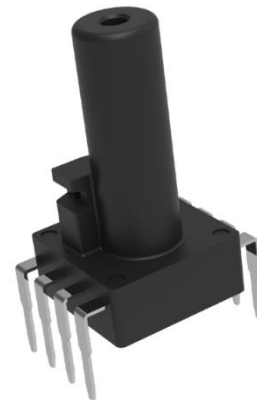

INDEX

1. PIN CONFIGURATION AND FUNCTIONS	3
2. ABSOLUTE MAXIMUM RATINGS	4
3. RECOMMENDED OPERATING CONDITIONS.....	4
4. SPECIFICATIONS	5
4.1. ELECTRICAL CHARACTERISTICS.....	5
4.2. I ² C ELECTRICAL CHARACTERISTICS	5
5. FUNCTION DESCRIPTION	6
5.1. OVERVIEW.....	6
5.2. ANALOG OUTPUT TRANSFER FUNCTION	6
5.3. DIGITAL OUTPUT TRANSFER FUNCTION	7
5.4. FREQUENCY OUTPUT TRANSFER FUNCTION	8
5.5. I ² C INTERFACE	8
6. TYPICAL APPLICATION	10
6.1. APPLICATION CIRCUIT.....	10
7. PACKAGE INFORMATION.....	11
7.1. PACKAGE SIZE.....	11
7.2. RECOMMENDED FOOTPRINT	11
8. ORDER INFORMATION	12
9. IDENTIFICATION CODE	12
10. SOLDERING PARAMETERS	13
11. TUBE INFORMATION	14
12. REVISION HISTORY	14
NOTES:	15

1. Pin Configuration and Functions

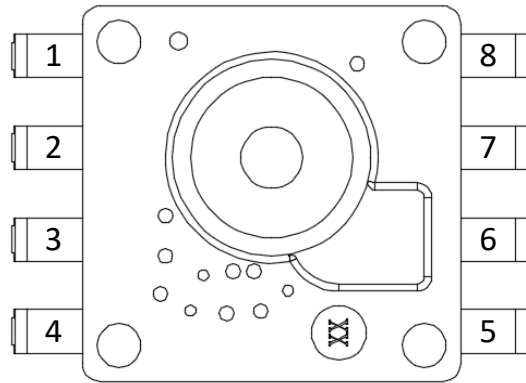

Fig 1.1 NSPGD1 series pin definition (top view)

Table 1.1 analog/ frequency output pin description

<i>Pin NO.</i>	<i>Pin name</i>	<i>Description</i>
1	NC	NC
2	VDD	Power supply
3	GND	Ground
4	VOUT / FREQ	Output Voltage / Frequency
5	NC	NC
6	NC	NC
7	NC	NC
8	NC	NC

Table 1.2 digital output pin description

<i>Pin NO.</i>	<i>Pin name</i>	<i>Description</i>
1	NC	NC
2	NC	NC
3	SDA	I ² C data signal
4	SCL	I ² C clock signal
5	VDD	Power supply
6	GND	Ground
7	NC	NC
8	NC	NC

2. Absolute Maximum Ratings

Parameters	Symbol	Min	Typ	Max	Unit	Comments
Supply voltage	VDD _{max}	-0.3		6.5	V	
Analog pin voltage		-0.3		VDD+0.3	V	
Analog output current limit				25	mA	
Proof pressure	P _{proof}	30			kPa	
Burst pressure	P _{burst}	50			kPa	
Storage temperature	T _{stg}	-30		100	°C	
ESD susceptibility	HBM		2		kV	

3. Recommended Operating Conditions

Parameters	Symbol	Min	Typ	Max	Unit	Comments
Supply voltage	VDD	3	3.3	3.6	V	analog output
		4.5	5	5.5		digital output
		4.8	5	5.2		frequency output
Operating pressure	P _{amb}	-10		10	kPa	
Operating temperature	T _{opr}	0		70	°C	

4. Specifications

4.1. Electrical Characteristics

Parameters	Symbol	Min	Typ	Max	Unit	Comments
Power on reset	VDD _{POR}		2		V	
Operating current	I _{avdd}		2.5		mA	Operation mode
				200	nA	Standby mode in digital output
Accuracy ^{1,2}	ACC		1%		%FS	Initially accuracy
			2.5%		%FS	Full life accuracy
ADC resolution	RES _{RAW}		24		Bits	
PSRR	PSRR	90	120		dB	
DAC resolution			12		Bits	
Output load resistance	R _{load}	1			kOhm	Analog output
Output load capacitance	C _{load}			15	nF	Analog output
Response Time	T _{RESP}		10		ms	
DAC Output RMS noise	V _{rms}			0.5	ms	
EEPROM data retention	T _{live}	10			a	@125°C

- Accuracy includes non-linearity, temperature, pressure hysteresis, temperature hysteresis;
- Full life accuracy based on the 500 hour of HTOL, LTOL, HTSL, TH(85°C/85%RH), and PCT testing;

4.2. I²C Electrical Characteristics

Parameters	Symbol	Min	Typ	Max	Unit	Comments
Clock frequency	f _{SCLB}			400	kHz	
SCL low pulse	t _{BLowB}	1.3			μs	
SCL high pulse	t _{BHighB}	0.6			μs	
SDA setup time	t _{BSUDATB}	0.1			μs	
SDA hold time	t _{BHDDATB}	0.0			μs	
Setup time for a repeated start condition	t _{BSUSTAB}	0.6			μs	
Hold time for a start condition	t _{BHDSTAB}	0.6			μs	
Setup time for a stop condition	t _{BSUSTOB}	0.6			μs	
Time before a new transmission can start	t _{BUBFB}	1.3			μs	

5. Function Description

5.1. Overview

NSPGD1 uses a MEMS piezoresistive gauge pressure sensor element as a pressure sensitive component that provide an original signal output that is proportional to ambient pressure. The built-in conditioning IC drives the sensitive component and amplifies, temperature compensates, and linearizes the original signal to output a signal that is linear with the applied pressure.

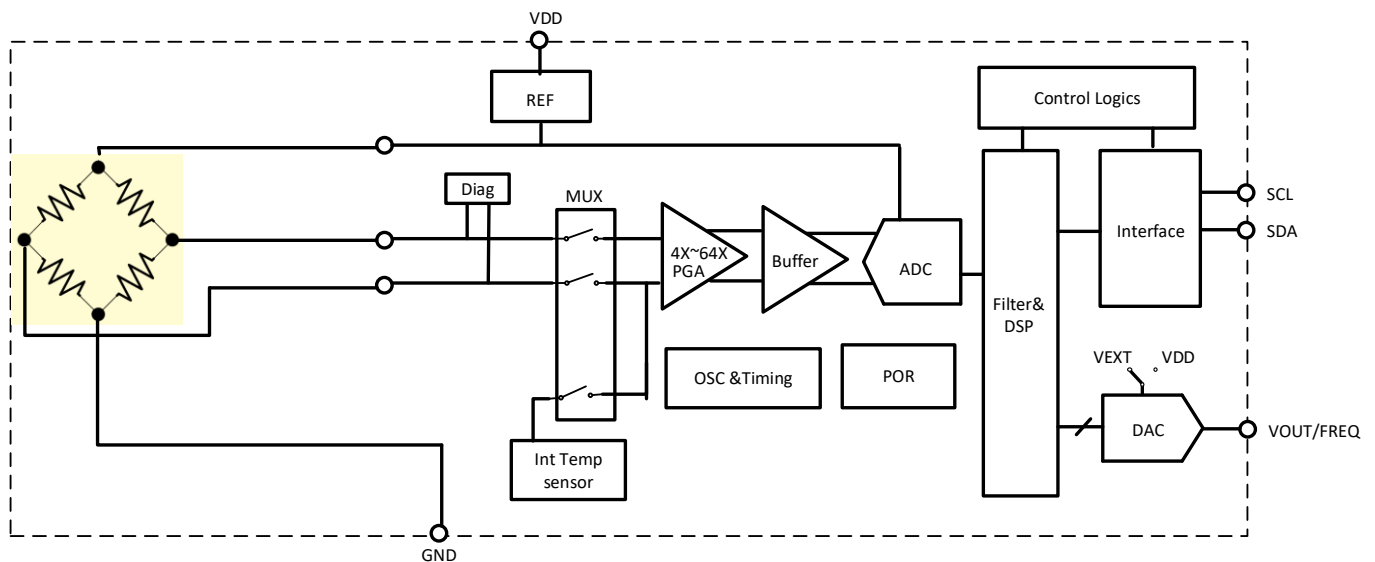

Fig 5.1 Product Function Block Diagram

5.2. Analog output transfer function

$$VOUT = (A \times P + B) \times 5 \text{ @absolute analog output, VDD=5V}$$

$$VOUT = (A \times P + B) \times 3.3 \text{ @absolute analog output, VDD=3.3V}$$

$$VOUT = (A \times P + B) \times VDD \text{ @ratiometric analog output}$$

Note:

VOUT is the analog output, unit is V;

P is the pressure value, gauge pressure, unit is kPa/mmH2O;

Table 5.1 Analog Output Transfer Function Coefficient

Product NO.	Pressure range		Output range		Gain and offset	
	P _L	P _H	O _L	O _H	A	B
NSPGD1F002RT02	0kPa	2kPa	0.1*VDD	0.9*VDD	0.4	0.1

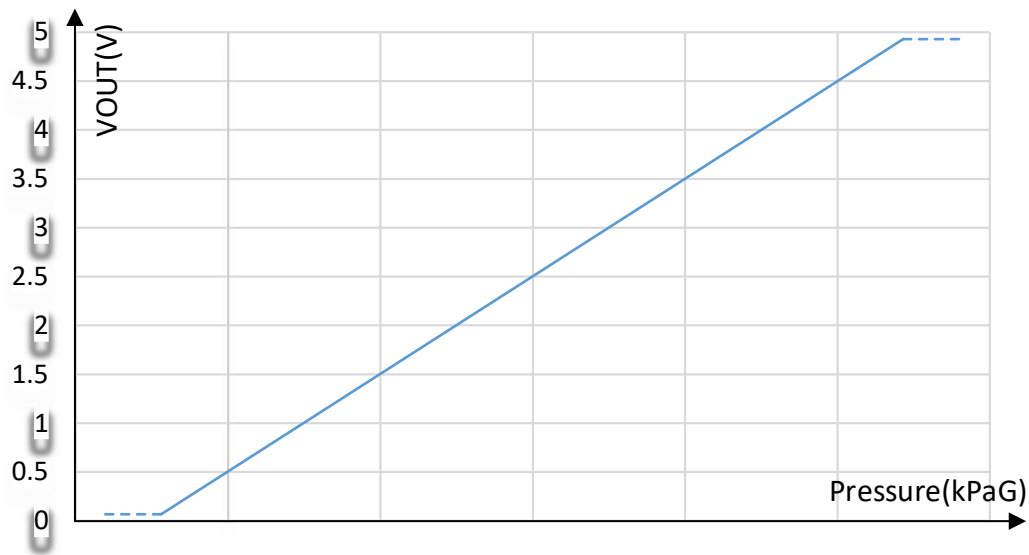

Fig 5.2 Analog Output Transfer Function

5.3. Digital output transfer function

$$Code = (A \times P + B) * 8388607$$

Code is the register 0x06~0x08 value;

P is the pressure value, gauge pressure, unit is kPa/mmH2O;

Table 5.2 Digital Output Transfer Function Coefficient

Product NO.	Pressure range		Output range		Gain and offset	
	P _L	P _H	O _L	O _H	A	B
NSPGD1F006DT04	0kPa	6kPa	838861	7549746	0.13333	0.1

Register Map:

Addr	Bit Addr	Description	Default	Description
0x30	7 - 4	Reserve	4'b0000	Write with 0x0A to start a conversion, automatically come back to 0x02 after conversion ends.
	3	Sco	1'b0	
	2 - 0	Measurement_ctrl<2:0>	3'b000	
0x06	7 - 0	PDATA<23:16>	0x00	Output Pressure Data. Code = Data0x06*2 ¹⁶ + Data0x07*2 ⁸ + Data0x08;
0x07	7 - 0	PDATA<15:8>	0x00	
0x08	7 - 0	PDATA<7:0>	0x00	

For example:

If the value of the registers 0x06、0x07、0x08 are 0x3F, 0xFF, 0xFF, according to NSPGD1F006DT04 transfer function, Code = 4194303, P(kPa) = (4194303/8388607-B)/A, and finally get the value of pressure about 3kPa.

5.4. Frequency output transfer function

$$FREQ = (A \times P + B) \times F.S.$$

Note:

- 1) FREQ is the frequency output, unit is kHz;
- 2) P is the pressure value, gauge pressure, unit is kPa/mmH2O;
- 3) F.S. is the full scale of frequency output. The chip can be configured with four full-scale frequencies, which are 250kHz, 125kHz, 61.5kHz, and 31.25kHz;

Table 5.3 Frequency Output Transfer Function Coefficient

Product NO.	Pressure range		Output range		Gain and offset		Full scale
	P _L	P _H	O _L	O _H	A	B	F.S.
NSPGD1F004FT12	0mmH2O	350mmH2O	3.125kHz	28.125kHz	0.002285714	0.1	31.25kHz

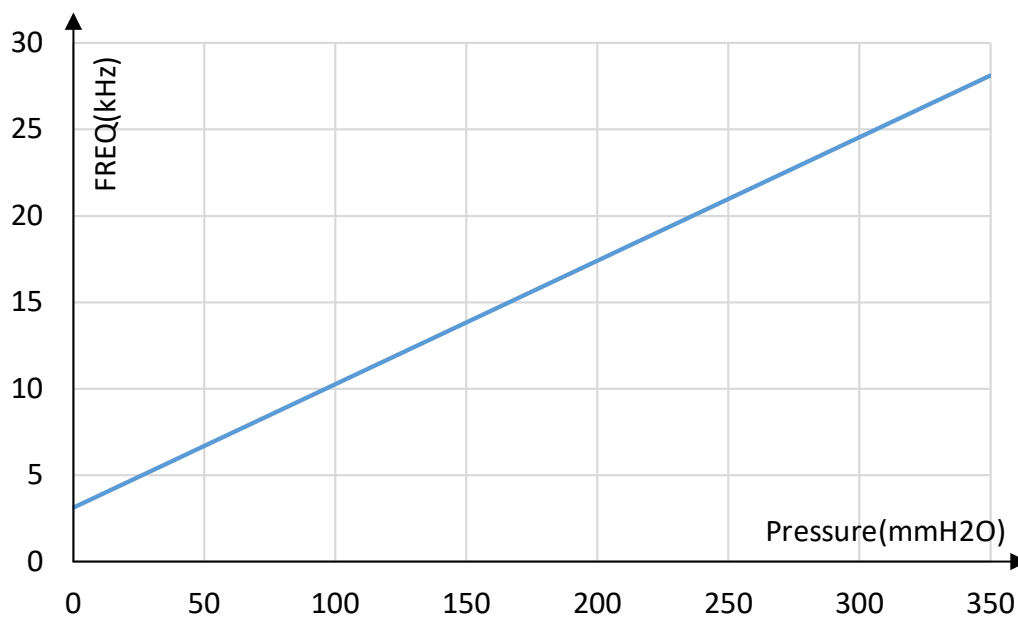

Fig 5.3 Frequency Output Transfer Function

5.5. I²C interface

I²C bus uses SCL and SDA as signal lines. Both lines are connected to VDD externally via pull-up resistors so that they are pulled high when the bus is free. The I²C device address of NSPGD1 is shown below.

Table 5.4 I²C address

A7	A6	A5	A4	A3	A2	A1	W/R
1	1	1	1	1	1	1	0/1

The IIC interface protocol has special bus signal conditions. Start (S), stop (P) and binary data conditions are shown below. At start condition, SCL is high and SDA has a falling edge. Then the slave address is sent. After the 7 address bits, the direction control bit R/W selects the read or write operation. When a slave device recognizes that it is being addressed, it should acknowledge by pulling SDA low in the ninth SCL (ACK) cycle.

At stop condition, SCL is also high, but SDA has a rising edge. Data must be held stable at SDA when SCL is high. Data can change value at SDA only when SCL is low.

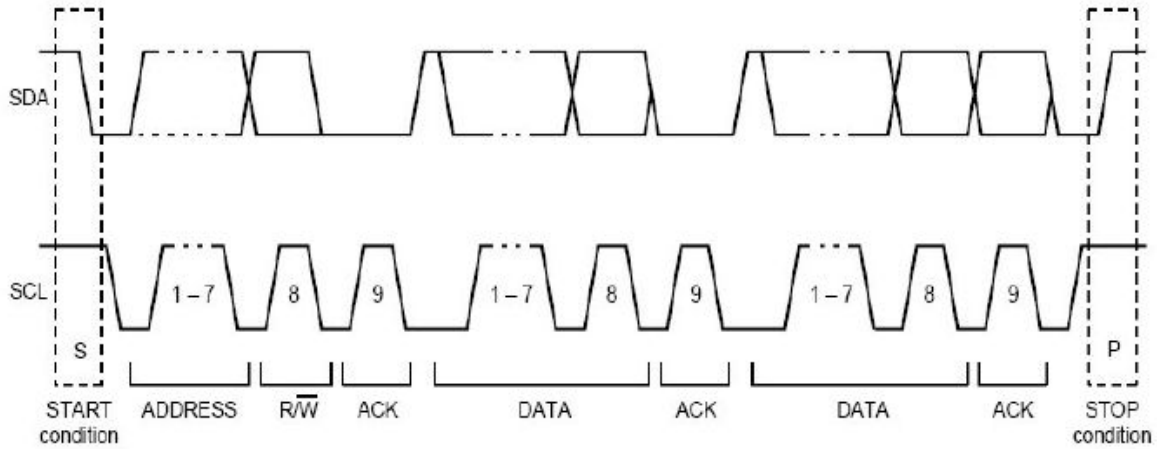

Fig 5.4 I²C Protocol

Byte Write

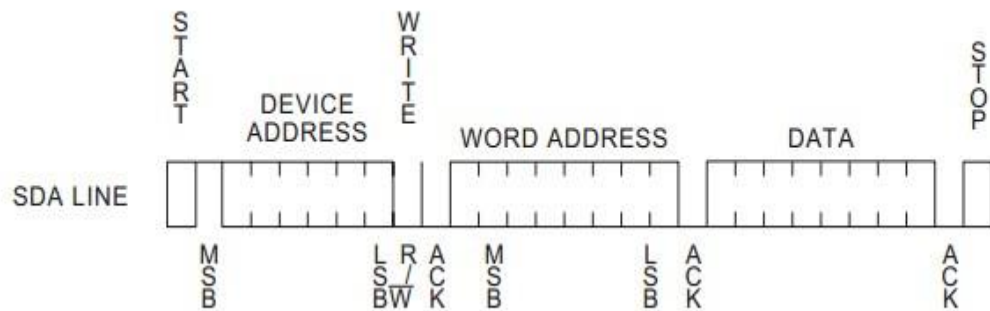

Fig 5.5 I²C Write Byte

Random Read

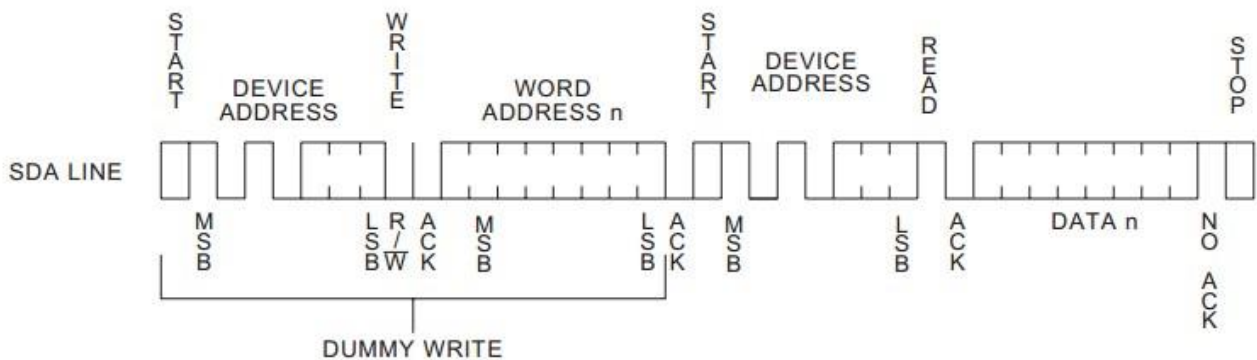

Fig 5.6 I²C Read Byte

6. Typical Application

6.1. Application circuit

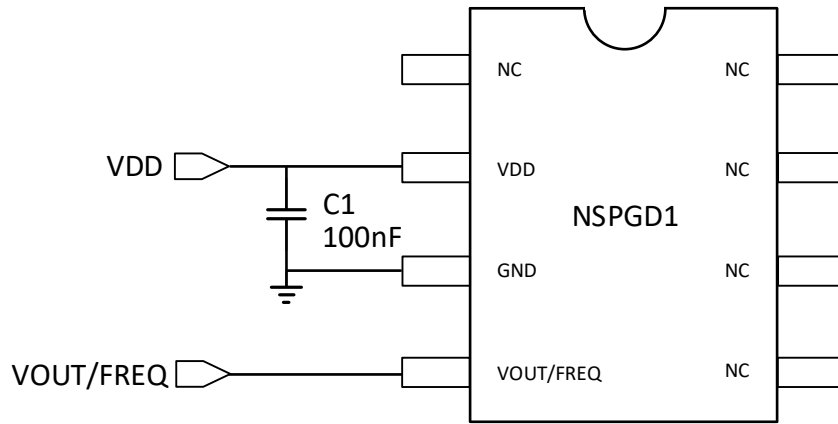

Fig 6.1 Analog/ Frequency Output Application Circuit

Note: For applications with higher ESD requirements, it is recommended that customers use the Fig 6.2 protection circuits.

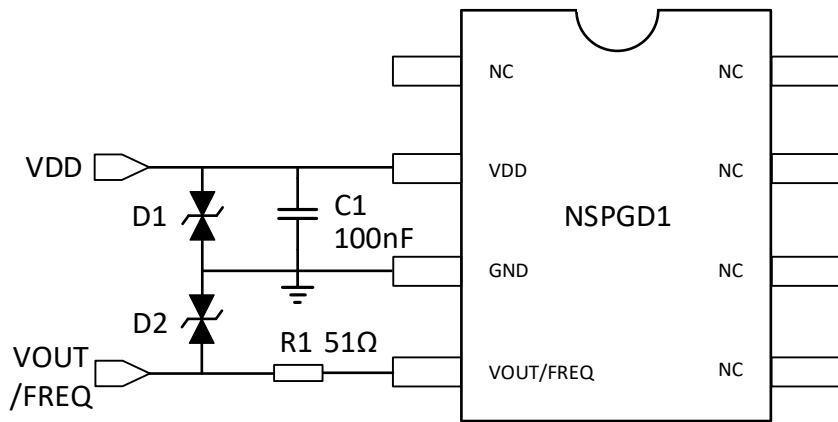

Fig 6.2 Analog/ Frequency Output Protection Circuit

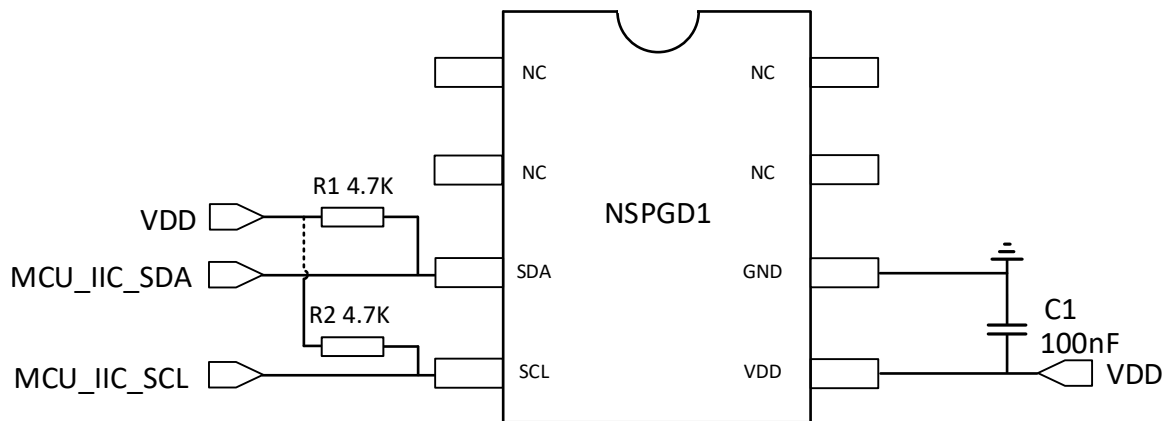

Fig 6.3 I²C Output Application Circuit

7. Package information

7.1. Package size

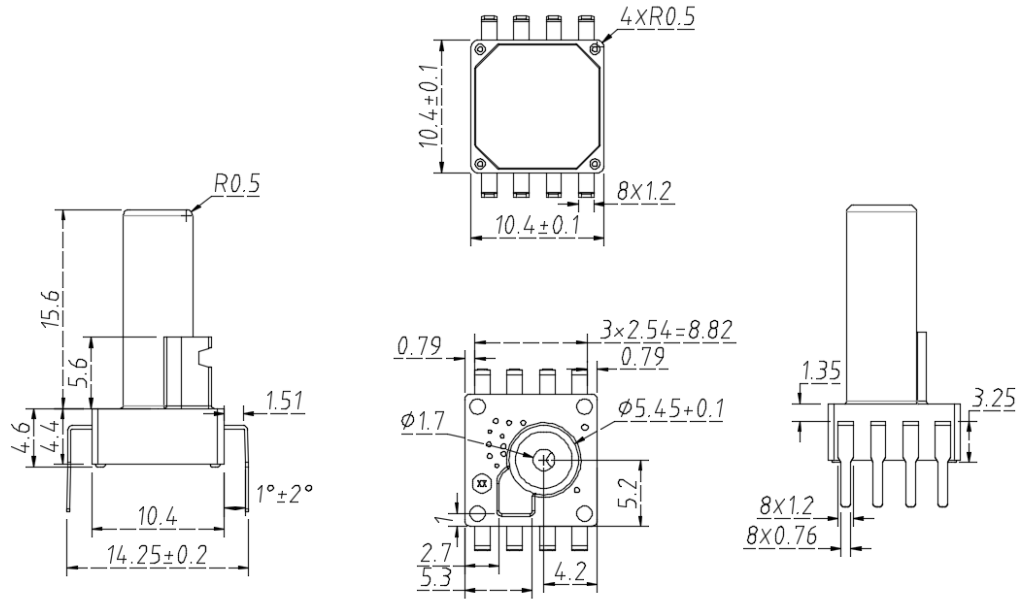

Fig 7.1 Package Outline mm

7.2. Recommended footprint

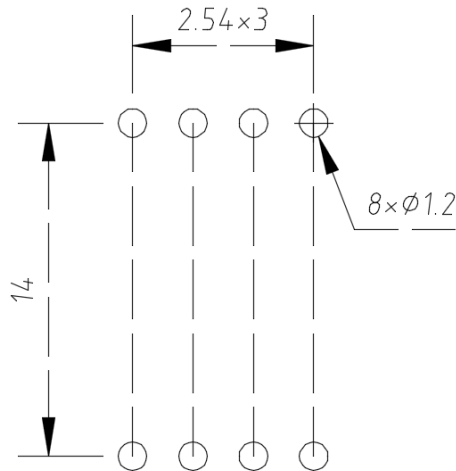
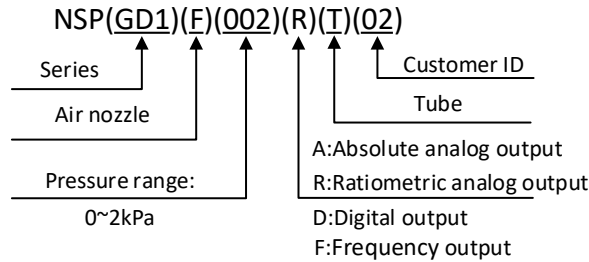

Fig 7.2 Footprint mm

8. Order Information

Product NO.	Output type	Pressure range		Output range		Clamp level		Gain and offset		supply voltage
		P _L	P _H	O _L	O _H	V _{CL}	V _{CH}	A	B	
NSPGD1F002RT02	Ratiometric	0kPa	2kPa	0.50V	4.50V	4.76%	94%	0.40000	0.10000	5V
NSPGD1F004RT03	Ratiometric	0kPa	3.92kPa	1.00V	4.92V	0%	100%	0.20000	0.20000	5V
NSPGD1F006DT04	I ² C	0kPa	6kPa	838861	7549746	NA	NA	0.13333	0.10000	5V
NSPGD1F003AT05	Absolute	0mmH2O	325mmH2O	0.50V	4.50V	0%	100%	0.00246	0.10000	5V
NSPGD1F005AT06	Absolute	0mmH2O	450mmH2O	0.50V	4.50V	0%	100%	0.00178	0.10000	5V
NSPGD1F010RT07	Ratiometric	0kPa	10kPa	0.50V	4.50V	0%	100%	0.08000	0.10000	5V
NSPGD1F010DT10	I ² C	0kPa	10kPa	838861	7549746	NA	NA	0.08000	0.10000	3.3V
NSPGD1F004FT12	Frequency	0mmH2O	350mmH2O	3.125kHz	28.125kHz	NA	NA	0.002285714	0.10000	5V
NSPGD1F005AT14	Absolute	0kPa	5kPa	0.5V	4.5V	0%	100%	0.16000	0.10000	5V
NSPGD1F004FT15	Frequency	0mmH2O	350mmH2O	43.410kHz	36.060kHz	NA	NA	-0.000336	0.694560	5.0V
NSPGD1F010AT16	Absolute	0kPa	10kPa	0.33V	2.97V	0%	100%	0.080000	0.100000	3.3V
NSPGD1F005DT17	I ² C	0kPa	5kPa	838861	7549746	NA	NA	0.160000	0.100000	5.0V
NSPGD1F001DT18	I ² C	0Pa	600Pa	838861	7549746	NA	NA	0.001333	0.100000	5.0V

Naming Convention:



9. Identification Code

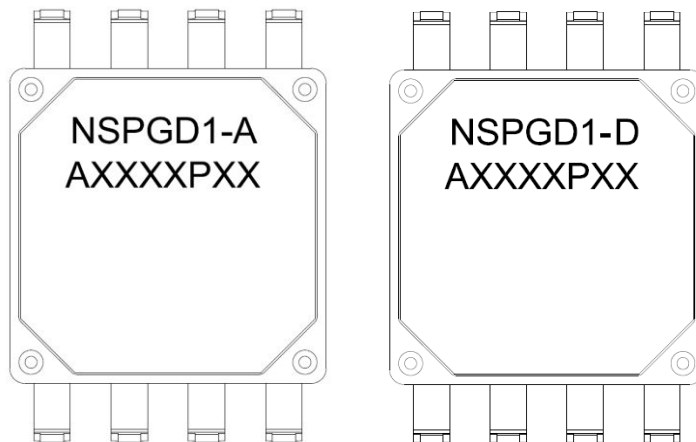

- NSPGD1: series name;
- A: analog output;
- D: digital output;
- AxxxxPxx: package date code;

10. Soldering Parameters

(1) Manual soldering

- Please use an electric soldering iron with a tip temperature of 300~350 °C to complete the soldering within 5 seconds.
- If a load is applied to the terminal during soldering, the sensor output may change.
- Please keep the solder tip clean and avoid using corrosive flux.

(2) Wave soldering

- Please keep the wave solder tank temperature below 255 °C and complete the soldering within 5 seconds.
- Since the MEMS pressure sensor is sensitive to temperature, it is recommended to verify the parameters of the wave soldering equipment in small batches, and then produce in large quantities after confirming the product performance.

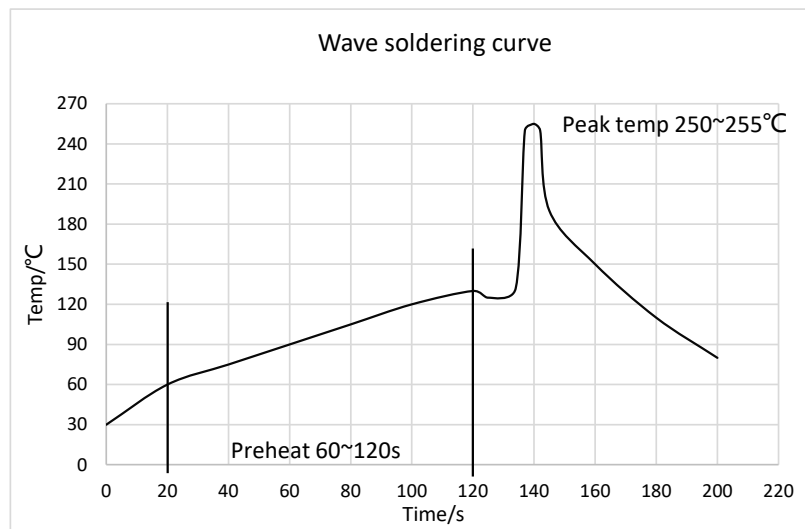

Fig 10.1 Wave soldering curve

Table 10.1 Wave Soldering parameter

Wave Soldering Condition		Lead-free assembly
Preheat	Temperature Min	110°C
	Temperature Max	130°C
	Time (min to max)	60~120s
Preheat average ramp up rate		1~3 °C/sec
Wave soldering Peak Temperature		250~255°C
Time of peak Temperature		<5sec
Chain speed		1000~1300mm/min

(3) Rework soldering

- Please use 300~350 °C soldering iron tip to complete the repair at a time.
- Electrostatic protection shall be provided during repair, and the sensor pins shall not be directly touched by hands to prevent electrostatic damage.

(4) Circuit board protective paint

- When applying circuit board protective paint after soldering, avoid blocking the atmospheric reference port next to the sensor air nozzle, otherwise the sensor output will be abnormal.

11. Tube information

This Series product using tube package, each tube contains 50ea devices. There are 10 tubes per box, and the minimum order quantity is 1000 EA. Each tube has a blue plug as the bottom and a white plug as the top. The schematic diagram of tube is as follows:

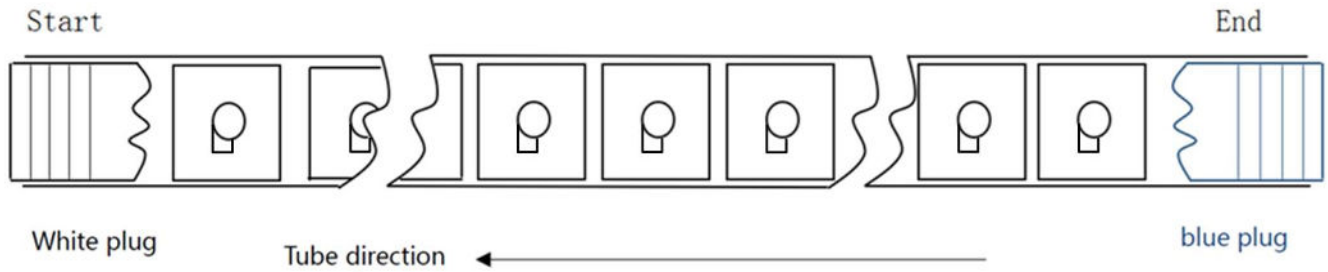

12. Revision History

Revision	Description	Date
1.0	Initial version.	2021/3/25
1.1	Add Frequency output type, Add Protection Circuit, update order Information.	2022/2/7
1.2	Add Soldering Parameters, update order Information, update package information, add important notice.	2022/6/1

Notes:1. I²C code

```
void IIC_Init(void)
{
    SCL_H;
    SDA_H;
    SCL_W;
    SDA_W;
}
```

```
void IIC_Start(void)
{
    SDA_W;
    SCL_H;
    SDA_H;
    delay10us();
    SDA_L;
    delay10us();
}
```

```
void IIC_Stop(void)
{
    SCL_L;
    delay10us();
    SCL_H;
    SDA_W;
    SDA_L;
    delay10us();
    SDA_H;
    delay10us();
}
```

```
void IIC_ACK(void)
{
    SDA_W;
    SDA_L;
    SCL_H;
    delay10us();
    SCL_L;
}
```

```
void IIC_NACK(void)
{
    SDA_W;
    SDA_H;
    SCL_H;
    delay10us();
}
```

```
SCL_L;
}

uchar IIC_Wait_ACK(void)
{
    int ErrTime=0;
    SDA_R;
    SCL_H;
    delay10us();
    while(Read_SDA)
    {
        ErrTime++;
        if(ErrTime>200)
        {
            IIC_Stop();
            return 1;
        }
    }
    SCL_L;
    SDA_W;
    SDA_L;
    delay10us();
    return 0;
}

void IIC_Send(uchar IIC_Data)
{
    uchar i;
    SDA_W;
    SCL_L;
    delay10us();
    for(i=0;i<8;i++)
    {
        if((IIC_Data&0x80)>>7)
            SDA_H;
        else
            SDA_L;
        IIC_Data<<=1;
        SCL_H;
        delay10us();
        SCL_L;
        delay10us();
    }
}

uchar IIC_Receive(uchar ACK)
{
    uchar i,Receive_Data=0x00;
    SDA_R;
```



```
    for(i=0;i<8;i++)
    {
        SCL_L;
        delay10us();
        SCL_H;
        Receive_Data<<=1;
        if(Read_SDA==1)
            Receive_Data++;
        else
            ;
        delay10us();
    }
    SCL_L;
    delay10us();
    if(ACK==0x01)
        IIC_ACK();
    else
        IIC_NACK();
    return Receive_Data;
}

void NSPGD1_Write_Byte(uchar WriteAddr,uchar WriteData)
{
    uchar flag;
    IIC_Start();
    IIC_Send(0xFE|0x00);
    IIC_Wait_ACK();
    IIC_Send(WriteAddr);
    IIC_Wait_ACK();
    IIC_Send(WriteData);
    IIC_Wait_ACK();
    IIC_Stop();
}

void NSPGD1_Read_Byte(uchar ReadAddr, uchar *pBuffer)
{
    IIC_Start();
    IIC_Send(0xFE|0x00);
    IIC_Wait_ACK();
    IIC_Send(ReadAddr);
    IIC_Wait_ACK();
    IIC_Start();
    IIC_Send(0xFE|0x01);
    IIC_Wait_ACK();
    pBuffer[0]=IIC_Receive(0);
    IIC_Stop();
}

void NSPGD1_Read_3Byte(uchar ReadAddr,uchar *pBuffer)
```

```
{
    IIC_Start();
    IIC_Send(0xFE|0x00);
    IIC_Wait_ACK();
    IIC_Send(ReadAddr);
    IIC_Wait_ACK();
    IIC_Start();
    IIC_Send(0xFE|0x01);
    IIC_Wait_ACK();
    pBuffer[0]=IIC_Receive(1);
    pBuffer[1]=IIC_Receive(1);
    pBuffer[2]=IIC_Receive(0);
    IIC_Stop();
}

Void Main()
{
    uChar PData[3]={0,0,0};
    IIC_Init();
    NSPGD1_Write_Byte(0x30,0x0A);
    Delay_3ms();
    NSPGD1_Read_3Byte(0x06,PData);
}
```

IMPORTANT NOTICE

The information given in this document shall in no event be regarded as any warranty or authorization of, express or implied, including but not limited to accuracy, completeness, merchantability, fitness for a particular purpose or infringement of any third party's intellectual property rights.

You are solely responsible for your use of Novosense' products and applications, and for the safety thereof. You shall comply with all laws, regulations and requirements related to Novosense's products and applications, although information or support related to any application may still be provided by Novosense.

The resources are intended only for skilled developers designing with Novosense' products. Novosense reserves the rights to make corrections, modifications, enhancements, improvements or other changes to the products and services provided. Novosense authorizes you to use these resources exclusively for the development of relevant applications designed to integrate Novosense's products. Using these resources for any other purpose, or any unauthorized reproduction or display of these resources is strictly prohibited. Novosense shall not be liable for any claims, damages, costs, losses or liabilities arising out of the use of these resources.

For further information on applications, products and technologies, please contact Novosense (www.novosns.com).

Suzhou Novosense Microelectronics Co., Ltd