

## Product Overview

NSPAS3 is a calibrated absolute pressure sensor series product launched by NOVOSENSE for vacuum boost, and Auto TMAP market. This series uses an automotive-grade ASIC to calibrate and compensate the MEMS sensor element, the pressure signal from 10kPa to 400kPa can be converted into an analog output signal (0~5V) with a customizable output range. While ensuring the reliability of the product, the two chips are integrated and packaged, reduces the package size greatly. This series provides outstanding performance in terms of initial accuracy and suits applications with harsh automotive temperature and stress conditions needing small drift over lifetime. Reliability test according to AEC-Q100 standard.

## Key Features

- High precision pressure sensing  
Better than  $\pm 1\%$ F.S. (0°C to 85°C)  
Better than  $\pm 1.5\%$ F.S. (-40°C to 130°C)
- Large temperature range -40°C to 130°C(168H@140°C)
- Over-voltage and Reverse voltage protection  
between -24V to 28V
- Directly supplied by high voltage up to 18V (absolute analog output)
- Better than 0.8ms response time
- Ratio-metric/Absolute analog output
- Clamping
- AEC-Q100 qualified

## Applications

- Automotive applications (manifold air pressure measurement)
- Industrial control
- vacuum boost applications
- Battery pressure sensor
- Motorcycle applications
- Consumer applications
- Weather stations
- Altimeters

## Device Information

<i>Part Number</i>	<i>Package</i>	<i>Body Size</i>
NSPAS3	7070SOP8	8.6mm × 7.0mm

## Outline

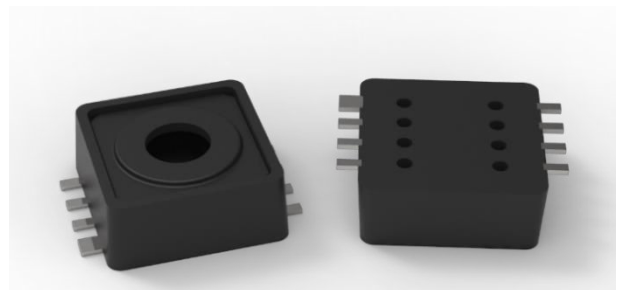

## INDEX

1. PIN CONFIGURATION AND FUNCTIONS . . . . .	3
2. ABSOLUTE MAXIMUM RATINGS . . . . .	4
3. RECOMMENDED OPERATING CONDITIONS . . . . .	4
4. SPECIFICATIONS . . . . .	5
4.1. ELECTRICAL CHARACTERISTICS . . . . .	5
5. FUNCTION DESCRIPTION . . . . .	6
5.1. OVERVIEW . . . . .	6
5.2. TRANSFER FUNCTION . . . . .	6
5.3. ACCURACY . . . . .	7
5.4. ALARM . . . . .	9
6. TYPICAL APPLICATION . . . . .	9
6.1. APPLICATION CIRCUIT . . . . .	9
6.2. RECOMMENDED FOOTPRINT . . . . .	10
6.3. SOLDERING PARAMETERS . . . . .	10
7. PACKAGE INFORMATION . . . . .	11
8. ORDER INFORMATION . . . . .	12
9. IDENTIFICATION CODE . . . . .	13
10. TAPE/REEL INFORMATION . . . . .	14
11. REVISION HISTORY . . . . .	15

## 1. Pin Configuration and Functions

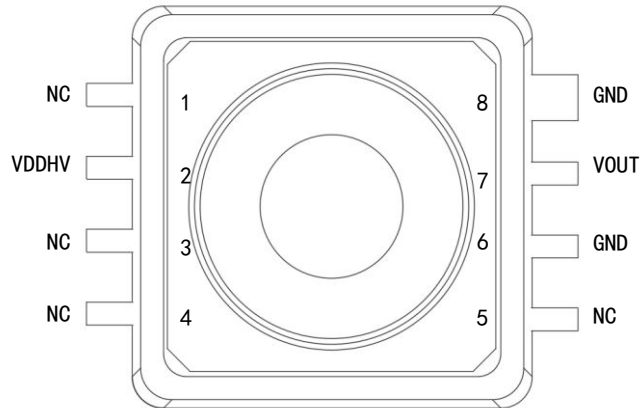

Fig 1.1 Pin Definition (Top view)

Table 1.1 Pin Description

<i>Pin NO.</i>	<i>Pin name</i>	<i>Description</i>
1	NC	No connect
2	VDDHV	Power supply with OVP/RVP
3	NC	No connect
4	NC	No connect
5	NC	No connect
6	GND	Ground
7	VOUT	Analog output
8	GND	Ground

## 2. Absolute maximum ratings

<i>Parameters</i>	<i>Symbol</i>	<i>Min</i>	<i>Typ</i>	<i>Max</i>	<i>Unit</i>	<i>Comments</i>
Supply voltage	VDDHV	-24		28	V	70°C, 1 hour
		-30		36	V	70°C, 1 minute
Analog pin voltage	VOUT	-0.3		5.3	V	25°C, VDDHV>5V
Analog output current limit				25	mA	
Proof pressure	P <sub>proof</sub>	1000			kPa	
Burst pressure	P <sub>burst</sub>	1500			kPa	
ESD susceptibility	HBM	±2			kV	
	CDM	±500			V	
Storage temperature	Tstg	-40		130	°C	

## 3. Recommended Operating Conditions

<i>Parameters</i>	<i>Symbol</i>	<i>Min</i>	<i>Typ</i>	<i>Max</i>	<i>Unit</i>	<i>Comments</i>
Supply voltage	VDDHV	4.5	5	5.5	V	
Operating pressure	P <sub>amb</sub>	10		400	kPa	
Operating temperature	Topr	-40		130	°C	168H@140°C

## 4. Specifications

### 4.1. Electrical characteristics

<i>Parameters</i>	<i>Symbol</i>	<i>Min</i>	<i>Typ</i>	<i>Max</i>	<i>Unit</i>	<i>Comments</i>
Output voltage range	V <sub>OUT</sub>	0.05		4.95	V	
Accuracy pressure	Acc <sub>P</sub>	-1%		1%	%F.S.	@0°C ~85°C
		-1.5%		1.5%	%F.S.	@-40°C ~130°C
Power on reset	V <sub>DDHV_POR</sub>		2.5		V	
Operating current	I <sub>avdd</sub>	2.7	3.1	3.5	mA	
Output RMS noise	V <sub>rms</sub>		0.5		mV	
Output load resistance	R <sub>load</sub>	1			kOhm	
Output load capacitance	C <sub>load</sub>			150	nF	
Output short current limit	I <sub>short_lmt</sub>	10		25	mA	Output short to V <sub>DDHV</sub> or GND
Clamp low level	V <sub>clampL</sub>	0%		50%	%V <sub>DDHV</sub>	
Clamp high level	V <sub>clampH</sub>	50%		100%	%V <sub>DDHV</sub>	
Clamp level error	ΔV <sub>clamp</sub>		40		mV	@V <sub>DDHV</sub> =5V
Power up time	T <sub>UP</sub>		10		ms	
Response time	T <sub>RESP</sub>		0.8		ms	
Diagnostic response time	T <sub>diag</sub>			1	ms	
EEPROM data retention	T <sub>live</sub>	10			years	@150°C

## 5. Function description

### 5.1. Overview

NSPAS3 uses a MEMS piezoresistive absolute pressure sensor element as a pressure sensitive component that provide an original signal output that is proportional to ambient pressure. The built-in conditioning IC drives the sensitive component and amplifies, temperature compensates, and linearizes the original signal to output a voltage signal that is linear with the applied pressure.

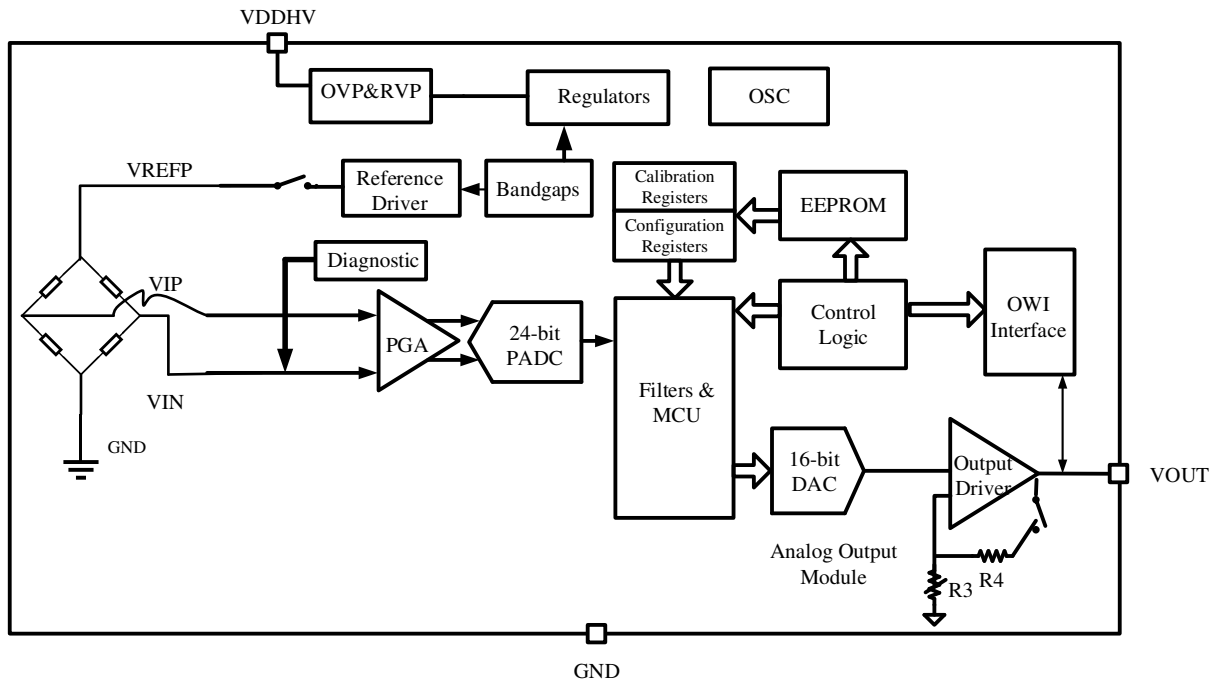

Fig 5.1 Product Function Block Diagram

### 5.2. Transfer function

NSPAS3 series device is fully calibrated on delivery. The sensor has a linear transfer function between the applied pressure and the output signal:

$$\text{Ratiometric: } VOUT = (A \times P + B) \times VDDHV$$

$$\text{Absolute: } VOUT = (A \times P + B) \times 5$$

Note: 1) P is the pressure value, absolute pressure, range: 10kPe~400kPa; the transfer function is only established in the pressure range.

2) VDDHV must in the operating voltage range;

Table 5.1 NSPAS3N115RRA1 transfer function coefficient

Product Type	Pressure range		Output range		Gain and offset	
	$P_L$	$P_H$	$O_L$	$O_H$	A	B
NSPAS3N115RRA1	10kPa	115kPa	0.4V	4.65V	0.008095	-0.00095

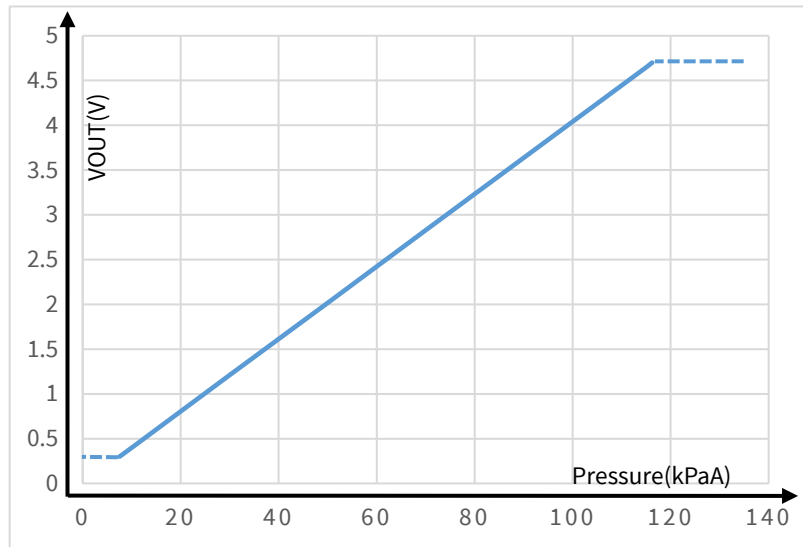

Fig 5.2 NSPAS3N115RRA1 transfer function

### 5.3. Accuracy

Factors affecting the accuracy of NSPAS3 series products include power supply voltage (ratiometric error), pressure, temperature and aging effects. Standard output refers to the theoretical voltage output calculated by the transfer function of the pressure in the range. The error equals the deviation between the measured output voltage value and the specified output voltage value. The accuracy in the following analysis is in a typical application circuit.

#### 5.3.1 Ratiometric Error

Ideally the sensor is ratiometric - the output (VOUT) scales by the same ratio that VDDHV increases or decreases. The ratiometric error is defined as the difference between the ratio that VDDHV changed and the ratio that VOUT changed, expressed as a percentage. The calculation formula is as follows:

$$E_{RAT}(\%) = \frac{V_{OUT}(@VDDHV) - V_{OUT}(@5V) \times \frac{VDDHV}{5V}}{5V} \times 100\%$$

The output voltage VOUT is ratiometric to VDDHV. VDDHV must be in the operating range.

Table 5.2 Ratiometric Output Error

Supply voltage (V)	Max. ratiometric error $E_{RAT}(\%)$ @ $VDDHV_{TYP}$
$VDDHV_{MIN}$	$\pm 0.5\%$
$VDDHV_{TYP}$	0
$VDDHV_{MAX}$	$\pm 0.5\%$

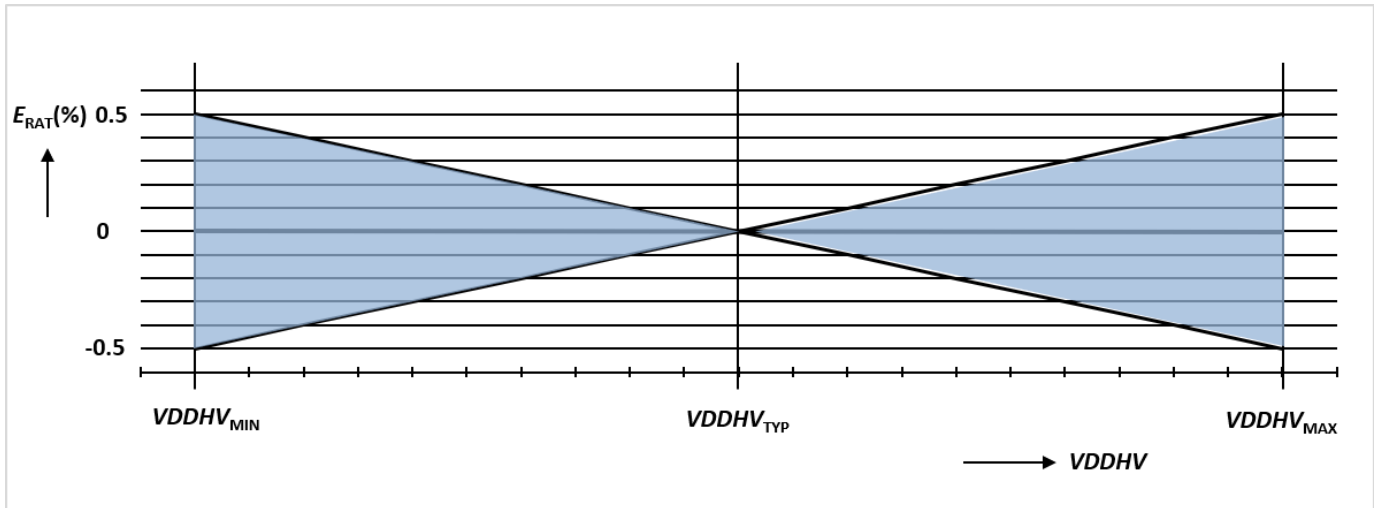

Fig 5.3 Ratiometric error

### 5.3.2 Overall Accuracy

The accuracy error includes errors introduced by all influencing factors within the operating range of pressure and temperature, including:

Pressure:

Output deviation from target transfer function over the specified pressure range

Temperature:

Output deviation over the temperature range

Aging:

Parameter drift over life time

Ps: Ratiometric signal error is not included in the overall accuracy. For error measurements, the supply voltage must have the nominal value ( $VDDHV = 5V$ ).

Table 5.3 Accuracy

<i>Temperature (°C)</i>	<i>Error Factor</i>
-40	1.50
0	1.00
85	1.00
125	1.50



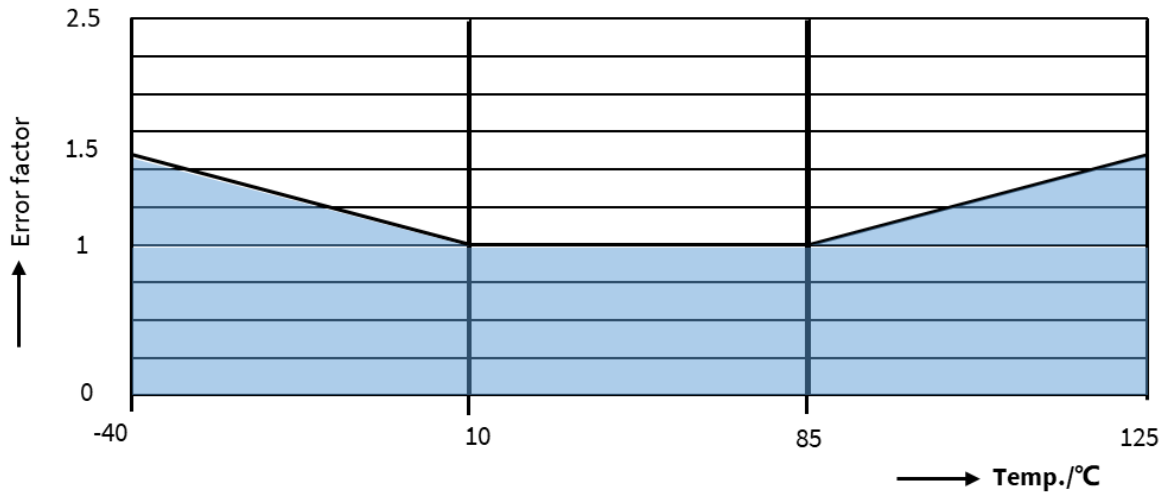

Fig 5.4 Accuracy for Pressure Acquisition

### 5.4. Alarm

NSPAS3 series have output alarm functions; when MEMS differential signal short to VDDHV/GND, the Vout will be pulled up to high voltage (4.9V@VDDHV=5V). The alarm function is OFF on default in order to optimize the response speed.

## 6. Typical Application

### 6.1. Application circuit

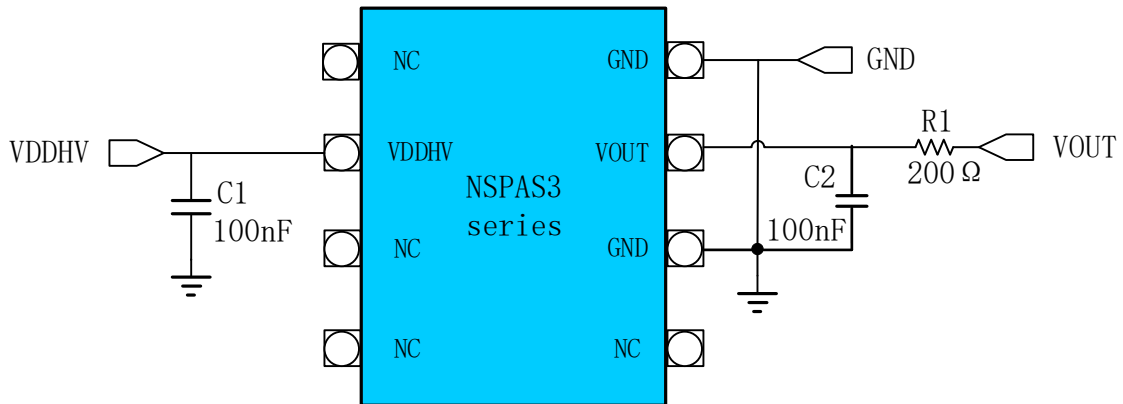

Fig 6.1 Application Circuit

Note :

- 1) For applications with higher ESD requirements, can add TVS between VOUT and GND and between VDDHV and GND.
- 2) Please contact NOVOSENSE for detailed peripheral recommended circuit.

6.2. Recommended footprint

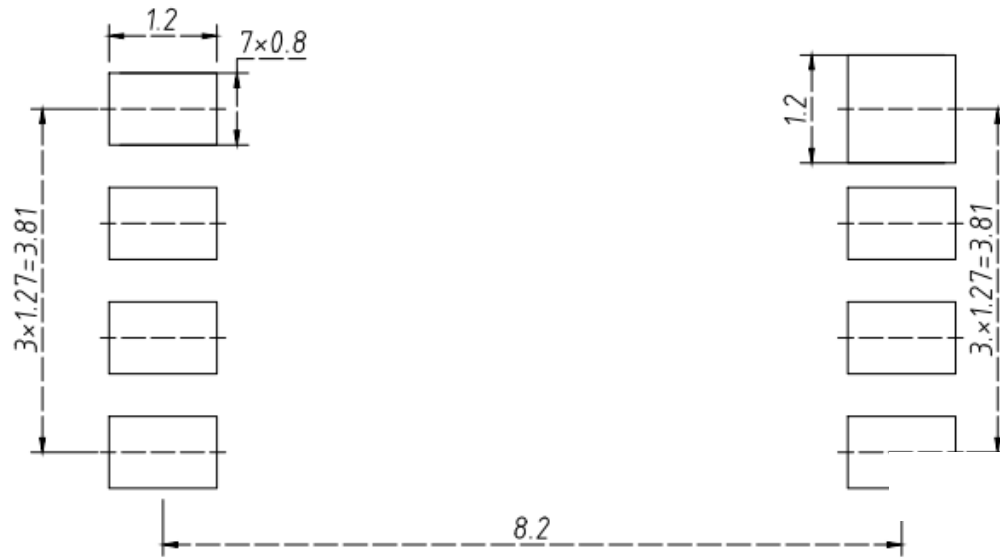

Fig 6.2 Footprint mm

6.3. Soldering Parameters

Table 6.1 Soldering Parameters

<i>Reflow Condition</i>		<i>Lead-free Assembly</i>
Pre Heat	Temperature Min (Ts(min))	150°C
	Temperature Max (Ts(max))	200°C
	Time (min to max) (ts)	60 – 180 secs
Average ramp up rate (Liquidus Temp (TL) to peak)		3°C/second max
Ts(max)to TL - Ramp-up Rate		3°C/second max
Reflow	Temperature (TL) (Liquidus)	217°C
	Time (min to max) (tl)	60 – 150 seconds
Peak Temperature (TP)		260°C
Time within 5°C of actual peak Temperature (tp)		20 – 40 seconds
Ramp-down Rate		6°C/second max
Time 25°C to peak Temperature (TP)		8 minutes Max.
Do not exceed		260°C

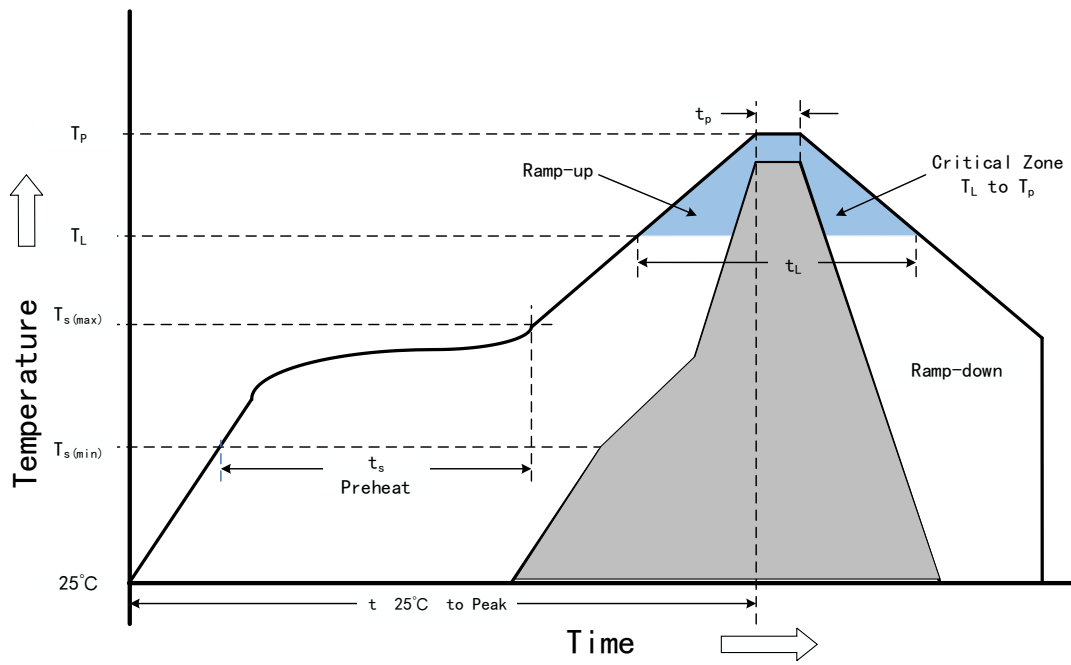

Fig 6.3 Soldering Profile

### 7. Package information

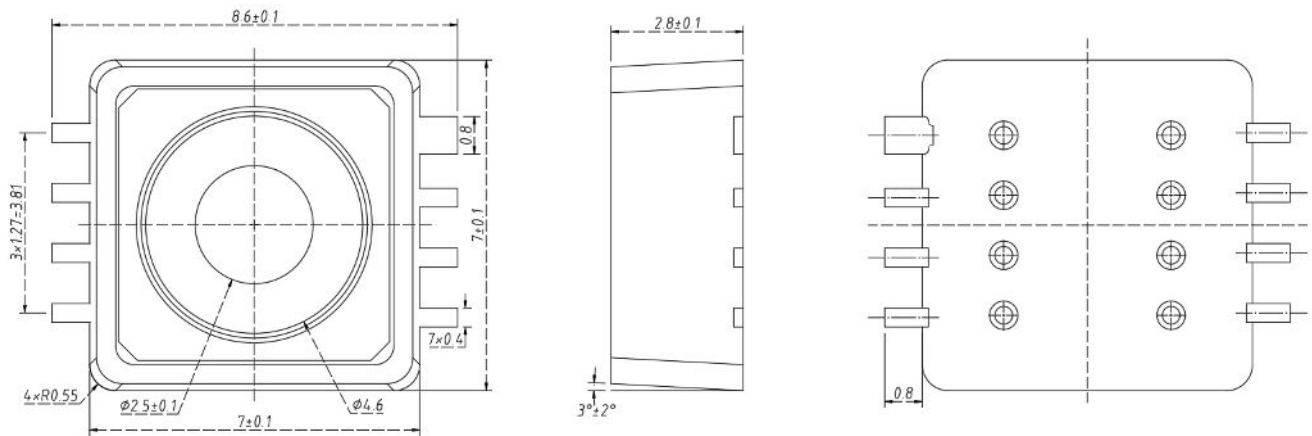

Fig 7.1 Package Outline mm

## 8. Order Information

Product Type	Output type	Pressure range		Output range (VDDHV=5V)		Clamp level		Gain and offset	
		$P_L$	$P_H$	$O_L$	$O_H$	$V_{CL}$	$V_{CH}$	A	B
NSPAS3N115RR01	Ratiometric	10.00kPa	115.00kPa	0.400V	4.650V	0.4V	4.65V	0.008095	-0.000952
NSPAS3N115RR02	Ratiometric	15.00kPa	115.00kPa	0.200V	4.700V	0.2V	4.7V	0.009000	-0.095000
NSPAS3N115RR03	Ratiometric	20.00kPa	115.00kPa	0.400V	4.650V	0.4V	4.65V	0.008947	-0.098947
NSPAS3N115RR04	Ratiometric	15.00kPa	115.00kPa	0.500V	4.500V	0.4V	4.6V	0.008000	-0.020000
NSPAS3N115RR05	Ratiometric	40.00kPa	115.00kPa	0.200V	4.700V	0.2V	4.7V	0.012000	-0.440000
NSPAS3N115RR06	Ratiometric	40.00kPa	115.00kPa	0.500V	4.500V	0.3V	4.7V	0.010667	-0.326667
NSPAS3N102RR07	Ratiometric	15.00kPa	102.00kPa	0.250V	4.850V	NA	NA	0.010575	-0.108621
NSPAS3N250RR08	Ratiometric	15.00kPa	250.00kPa	0.315V	4.310V	0.3V	4.7V	0.003400	0.012000
NSPAS3N100AR10	Absolute	10.00kPa	100.00kPa	1.217V	4.660V	NA	NA	0.007651	0.166889
NSPAS3N107RR11	Ratiometric	13.30kPa	106.70kPa	0.500V	4.600V	0.3V	4.8V	0.008779	-0.016767
NSPAS3N115RRA1	Ratiometric	10.00kPa	115.00kPa	0.400V	4.650V	0.3V	4.7V	0.008095	-0.000952
NSPAS3N250RRB1	Ratiometric	10.00kPa	250.00kPa	0.400V	4.650V	0.3V	4.7V	0.003542	0.044583
NSPAS3N300RRC1	Ratiometric	10.00kPa	300.00kPa	0.400V	4.650V	0.3V	4.7V	0.002931	0.050690
NSPAS3N150RRC2	Ratiometric	10.00kPa	150.00kPa	0.500V	4.500V	0.4V	4.6V	0.005714	0.042857
NSPAS3N115RRD1	Ratiometric	10.00kPa	115.00kPa	0.400V	4.650V	0.3V	4.8V	0.008095	-0.000952
NSPAS3N107RRD2	Ratiometric	13.30kPa	106.70kPa	0.500V	4.800V	0.3V	4.8V	0.009208	-0.022463
NSPAS3N250RRD3	Ratiometric	20.00kPa	250.00kPa	0.400V	4.650V	0.3V	4.8V	0.003696	0.006087
NSPAS3N107RRD4	Ratiometric	13.30kPa	106.70kPa	0.500V	4.600V	0.33V	4.73V	0.008779	-0.016767
NSPAS3N350RRD5	Ratiometric	10.00kPa	350.00kPa	0.368V	4.960V	NA	NA	0.002701	0.046588
NSPAS3N350RRD6	Ratiometric	44.80kPa	350.00kPa	0.500V	4.500V	0.3V	4.7V	0.002621	-0.017431
NSPAS3N120RRD7	Ratiometric	10.00kPa	120.00kPa	0.300V	4.800V	0.2V	4.85V	0.008182	-0.021818
NSPAS3N102RRD8	Ratiometric	20.00kPa	102.00kPa	0.512V	4.854V	0.25V	4.95V	0.010590	-0.109405
NSPAS3N165RRE1	Ratiometric	60.00kPa	165.00kPa	0.200V	4.800V	NA	NA	0.008762	-0.485714
NSPAS3N165RRE2	Ratiometric	60.00kPa	165.00kPa	0.132V	3.168V	NA	NA	0.008762	-0.485714
NSPAS3N400RRF1	Ratiometric	50.00kPa	400.00kPa	0.500V	4.500V	0.3V	4.7V	0.002286	-0.014286
NSPAS3N300RRF2	Ratiometric	20.00kPa	300.00kPa	0.400V	4.650V	0.3V	4.7V	0.003036	0.019286
NSPAS3N115RRG1	Ratiometric	20.00kPa	115.00kPa	0.400V	4.650V	0.3V	4.7V	0.008947	-0.098947
NSPAS3N102RRH1	Ratiometric	15.00kPa	102.00kPa	0.250V	4.950V	NA	4.95V	0.010805	-0.112069
NSPAS3N120RRK1	Ratiometric	12.00kPa	120.00kPa	0.493V	4.740V	NA	4.97V	0.007865	0.004222
NSPAS3N115RRK2	Ratiometric	15.00kPa	115.00kPa	0.180V	4.650V	0.1V	4.85V	0.008940	-0.098100
NSPAS3N120RRK3	Ratiometric	10.00kPa	120.00kPa	0.400V	4.710V	0.35V	4.8V	0.007836	0.001636
NSPAS3N350RRK4	Ratiometric	10.00kPa	350.00kPa	0.500V	4.500V	0.3V	4.7V	0.002353	0.076471
NSPAS3N120ARK5	Absolute	12.00kPa	120.00kPa	0.493V	4.740V	NA	4.97V	0.007865	0.004222
NSPAS3N100RRK6	Ratiometric	20.00kPa	100.00kPa	1.292V	4.460V	NA	NA	0.007920	0.100000
NSPAS3N160RRK7	Ratiometric	20.00kPa	160.00kPa	0.710V	4.510V	NA	4.77V	0.005429	0.033429
NSPAS3N120RRK8	Ratiometric	20.00kPa	120.00kPa	0.800V	4.700V	NA	4.9V	0.007800	0.004000
NSPAS3N241RRM1	Ratiometric	22.90kPa	241.30kPa	0.502V	4.510V	NA	4.78	0.003670	0.016349
NSPAS3N261RRM2	Ratiometric	10.32kPa	261.30kPa	0.500V	4.500V	NA	4.82	0.003188	0.067105
NSPAS3N391RRM3	Ratiometric	31.05kPa	391.30kPa	0.500V	4.500V	NA	4.6	0.002221	0.031048
NSPAS3N400RRM4	Ratiometric	50.00kPa	400.00kPa	0.500V	3.611V	NA	NA	0.001778	0.011114
NSPAS3N350RRM5	Ratiometric	10.00kPa	350.00kPa	0.400V	4.650V	0.3V	4.7V	0.002500	0.055000
NSPAS3N350RRM6	Ratiometric	44.80kPa	350.00kPa	0.500V	4.500V	0.375V	4.625V	0.002621	-0.017431

Product Type	Output type	Pressure range		Output range (VDDHV=5V)		Clamp level		Gain and offset	
		$P_L$	$P_H$	$O_L$	$O_H$	$V_{CL}$	$V_{CH}$	A	B
NSPAS3N115RRM7	Ratiometric	12.50kPa	115.00kPa	0.500V	4.500V	0.35V	4.65V	0.007805	0.002439
NSPAS3N300RRM8	Ratiometric	50.00kPa	300.00kPa	0.500V	4.500V	NA	NA	0.003200	-0.060000

Naming Convention:

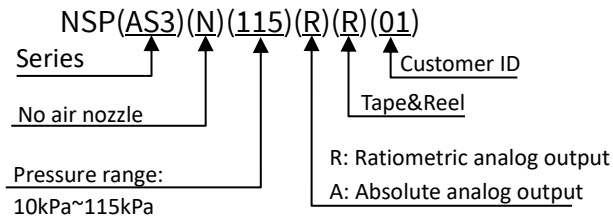

## 9. Identification Code

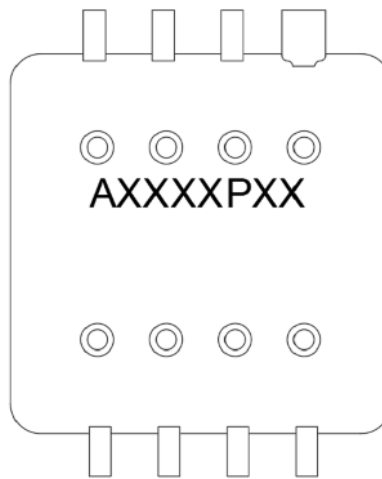

AxxxPxx: Package lot number.

### 10. Tape/Reel information

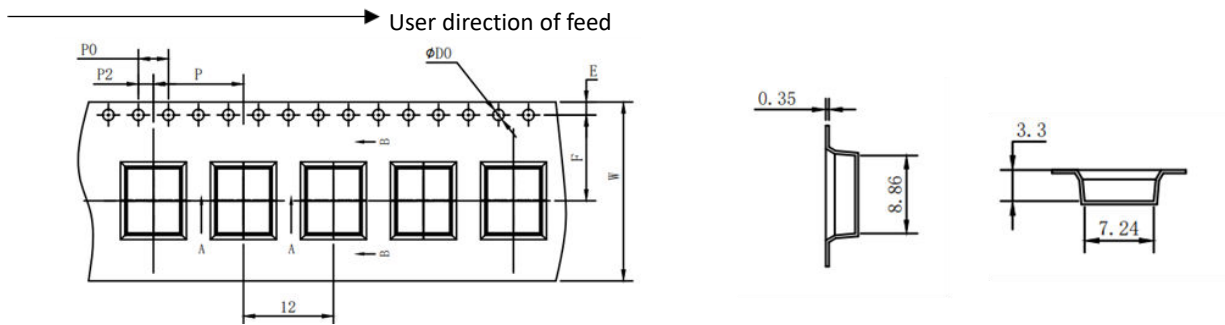

Series	E (mm)	F (mm)	P2 (mm)	D0 (mm)	P0 (mm)	10P0 (mm)	W (mm)	P (mm)	A0 (mm)	B0 (mm)	K0 (mm)	T (mm)
NSPAS3	1.75±0.10	11.5±0.10	2.0±0.10	1.5±0.1	4.0±0.1	40.0±0.20	24.0±0.30	12.0±0.1	7.24±0.1	8.86±0.10	3.30±0.10	0.35±0.05

There is no component at the head and the tail of each tape/reel, where the space is 40pcs, as shown in the following figure.

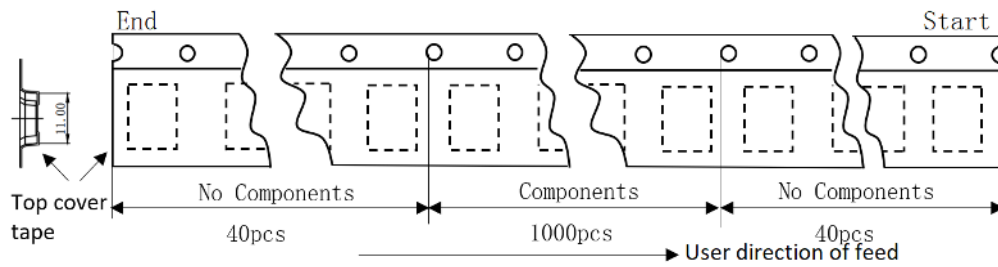

Pin8 is located at the second quadrant, as shown in the following figure.

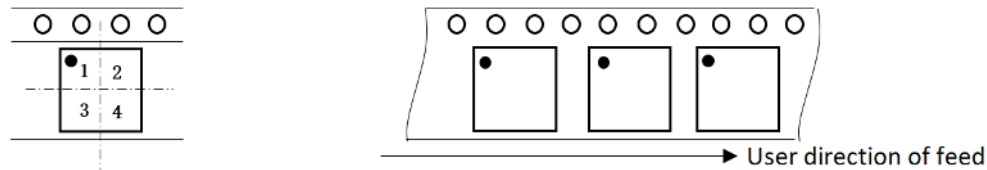

Minimum ordering quantity(MOQ):1000EA.

Standard pack quantity(SPQ): 1000EA.

## 11. Revision History

Revision	Description	Date
0.1	Initial Version.	2020/12/18
0.2	Update logo, font	2021/02/24
1.0	Release version	2021/4/1
1.1	Add part No.	2021/5/28
1.2	200Ω resistance is added to the typical application circuit; the selection table is updated to the official website;	2021/8/18
1.3	Add part No.	2021/11/24
1.4	Update clamp voltage level expression to percentage of VDDHV	2022/03/15
1.5	Update Tape/reel information Pin1 to Pin8	2022/04/25
1.6	Add soldering parameter; Update alarm function description;	2022/05/11

## IMPORTANT NOTICE

The information given in this document shall in no event be regarded as a guarantee of any warranty or authorization, express or implied, including but not limited to merchantability, fitness for a particular purpose or infringement of any third party's intellectual property rights.

You are solely responsible for your use of Novosense' products and applications. You shall comply with all laws, regulations and requirements related to Novosense's products and applications, although information or support related to any application may still be provided by Novosense.

The resources are intended only for skilled developers designing with Novosense' products. Novosense reserves the rights to make corrections, modifications, enhancements, improvements or other changes to the products and services provided. Novosense authorizes you to use these resources for the development of relevant applications of Novosense's products, other reproduction and display of these resources is prohibited. Novosense shall not be liable for any claims, damages, costs, losses or liabilities arising out of the use of these resources.

For further information on applications, products and technologies, please contact Novosense ([www.novosns.com](http://www.novosns.com)).

Suzhou Novosense Microelectronics Co., Ltd