

H1M170Q1K2

Silicon Carbide MOSFET
N-CHANNEL ENHANCEMENT MODE

Features

- Low On-Resistance and High Current Density
- Low Capacitance for High Frequency Operation
- Ultra-high Avalanche Ruggedness
- Positive Temperature Coefficient Device
- Low impedance Kelvin source pin-out
- RoHS Compliant and Halogen Free

Benefits

- Higher System Efficiency
- Increase Parallel Device Convenience
- Capable of 175°C High T_j Application
- Allow High Frequency Operation
- Realize Compact and Lightweight Systems

Applications

- Switching Mode Power Supply
- DC/DC Converters, UPS, and PFC
- Power Inverters
- Auxiliary Power Supplies
- Solar/Wind Renewable Energy

Product Summary

V_{DS}	1700V
$I_D(@25^\circ\text{C})$	3.6A
$R_{DS(on)}$	1.2Ω



Circuit Diagram

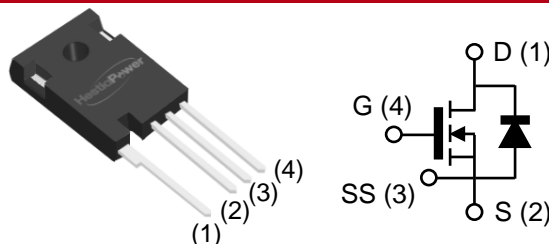

Part Number	Package	Marking
H1M170Q1K2	TO-247-4L	H1M170Q1K2

Description

The H1M170Q1K2 1700V, 1.2Ω silicon carbide power MOSFET is an N-channel enhancement mode device. Exploiting the outstanding wide bandgap material properties, this device shows high current density and great switching behavior. Thanks for the excellent thermal conductivity and many advantages of SiC, this device significantly improved in thermal capability and temperature independent switching behavior.

Absolute Maximum Ratings ($T_c = 25^\circ\text{C}$ unless otherwise specified)

Parameter	Symbol	Test Conditions	Value	Unit
Drain – Source Voltage	$V_{DS, max}$	$V_{GS}=0V, I_{DS}=100\mu A$	1700	V
Continuous Drain Current	I_D	$V_{GS}=20V, T_c=25^\circ\text{C}$	3.6	A
		$V_{GS}=20V, T_c=110^\circ\text{C}$	2.6	
Pulse Drain Current	$I_{D, pulse}$	t_{PW} limitation per Fig.15	4.2	
Avalanche energy, Single Pulse	E_{AS}	$V_{DD}=100V, I_D=1.8A$	40	mJ
Power Dissipation	P_D	$T_c=25^\circ\text{C}$	47	W
Recommend Gate Source Voltage	$V_{GS, op}$	Static, recommended DC operating values	-5 to 20	V
Maximum Gate Source Voltage	$V_{GS, max}$	Transient operating limit (AC $f > 1\text{Hz}$, duty cycle $< 1\%$)	-10 to 25	
Junction & Storage Temperature	T_j, T_{stg}		-55 to 175	$^\circ\text{C}$
Soldering Temperature	T_L		260	
Mounting Torque	M_D	M3 or 6-32 screw	1.0	Nm

Thermal Resistance

Parameter	Symbol	Min.	Typ.	Max.	Unit
Thermal Resistance, Junction to Case	$R_{\theta, jC}$		3.15		$^\circ\text{C/W}$

Electrical Characteristics ($T_c = 25^\circ\text{C}$ unless otherwise specified)

Parameter	Symbol	Test Conditions	Min.	Typ.	Max.	Unit
Drain-Source Breakdown Voltage	$V_{(BR)DSS}$	$V_{GS}=0V, I_{DS}=100\mu A$	1700			V
Gate Threshold Voltage	$V_{GS(th)}$	$V_{DS}=10V, I_{DS}=1mA$		3.0		V
Zero Gate Voltage Drain Current	I_{DSS}	$V_{DS}=1700V, V_{GS}=0V$		<1	100	μA
		$V_{DS}=1700V, V_{GS}=0V$ $T_j=175^\circ\text{C}$		10	500	
Gate-Source Leakage Current	I_{GSS}	$V_{GS}=20V, V_{DS}=0V$			250	nA
Drain-Source On-State Resistance	$R_{DS(on)}$	$V_{GS}=20V, I_{DS}=1A$		1.2	1.6	Ω
		$V_{GS}=20V, I_{DS}=1A,$ $T_j=175^\circ\text{C}$		2.4		
Transconductance	g_{fs}	$V_{DS}=12V, I_{DS}=2.5A$		0.9		S
Input Capacitance	C_{iss}	$V_{GS}=0V, V_{DS}=1000V$ $f=1MHz, V_{AC}=25mV$		233		pF
Output Capacitance	C_{oss}			13		
Reverse Transfer Capacitance	C_{rss}			4		
Effective Output Capacitance, Energy Related	$C_{o(er)}$		$V_{GS}=0V,$ $V_{DS}=0$ to 1000V		16	
Effective Output Capacitance, Time Related	$C_{o(tr)}$	$I_D=const., V_{GS}=0V,$ $V_{DS}=0$ to 1000V		19		
Turn On Delay Time	$t_{d(on)}$	$V_{DS}=1200V, V_{GS}=-4/20V,$ $I_D=1A, R_L=1200\Omega,$ $R_{G(ext)}=2.7\Omega$		28		ns
Rise Time	t_r			19		
Turn Off Delay Time	$t_{d(off)}$			76		
Fall Time	t_f			117		
C_{oss} Stored Energy	E_{oss}	$V_{GS}=0V, V_{DS}=1200V$ $f=1MHz, V_{AC}=25mV$		6		μJ
Turn-on Switching Energy	E_{on}	$V_{DS}=1200V, V_{GS}=0/20V,$ $I_D=1A,$		3*		
Turn-off Switching Energy	E_{off}	$R_{G(ext)}=2.7\Omega$		3*		
Internal Gate Resistance	$R_{G(int.)}$	$f=1MHz, V_{AC}=25mV$		8.6		Ω

*Based on the results of calculation, note that the energy loss caused by the reverse recovery of free-wheeling diode is not included in E_{on} .

Built-in SiC Diode Characteristics ($T_c = 25^\circ\text{C}$ unless otherwise specified)

Parameter	Symbol	Test Conditions	Typ.	Unit
Inverse Diode Forward Voltage	V_{SD}	$V_{GS}=0V, I_{SD}=0.25A$	3.0	V
Continuous Diode Forward Current	I_S	$V_{GS}=0V, T_c=25^\circ\text{C}$	4.9	A
Reverse Recovery Time	t_{rr}	$V_{GS}=0V,$	47	Ns
Reverse Recovery Charge	Q_{rr}	$I_{SD}=1A, V_{DS}=400V,$	10	nC
Peak Reverse Recovery Current	I_{rrm}	$di/dt=300A/\mu s$	0.75	A

Gate Charge Characteristics ($T_c = 25^\circ\text{C}$ unless otherwise specified)

Parameter	Symbol	Test Conditions	Value	Unit
Gate to Source Charge	Q_{GS}	$V_{DS}=1200V,$ $V_{GS}=-5/+20V,$ $I_D=1A$	6	nC
Gate to Drain Charge	Q_{GD}		14	
Total Gate Charge	Q_G		26	
Gate plateau voltage	V_{pl}		9.8	V

Typical Device Performance

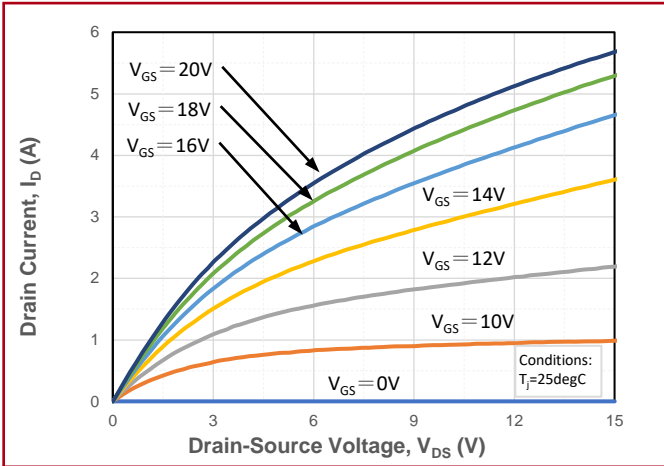

Fig.1 Forward Output Characteristics at $T_j = 25^\circ\text{C}$

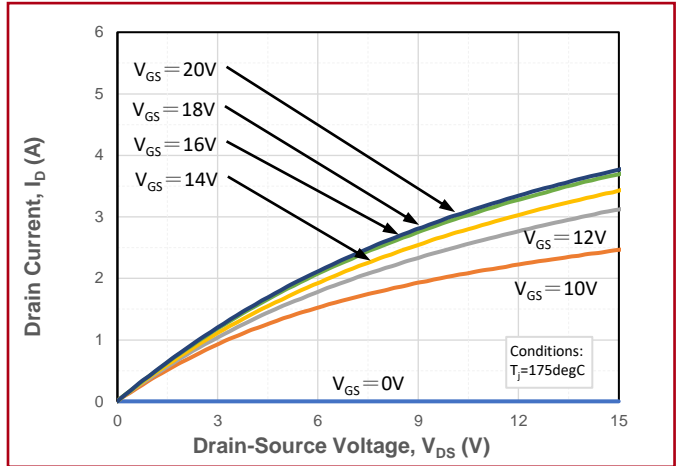

Fig.2 Forward Output Characteristics at $T_j = 175^\circ\text{C}$

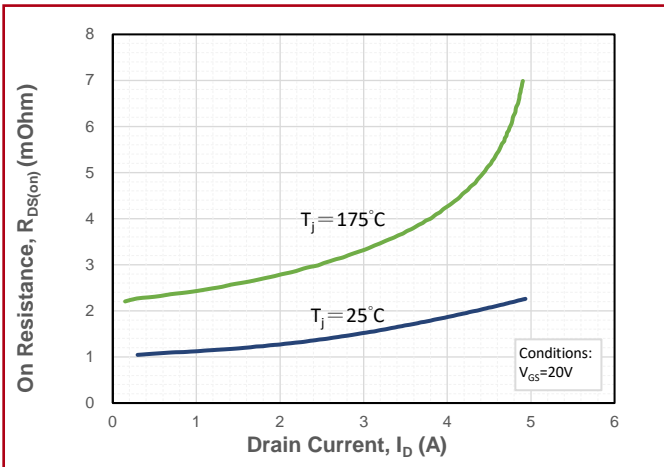

Fig.3 On-Resistance vs. Drain Current for Various T_j

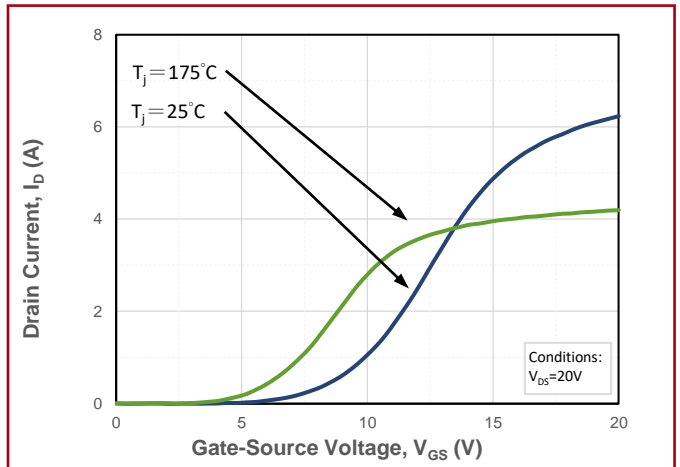

Fig.4 Transfer Characteristics for Various T_j

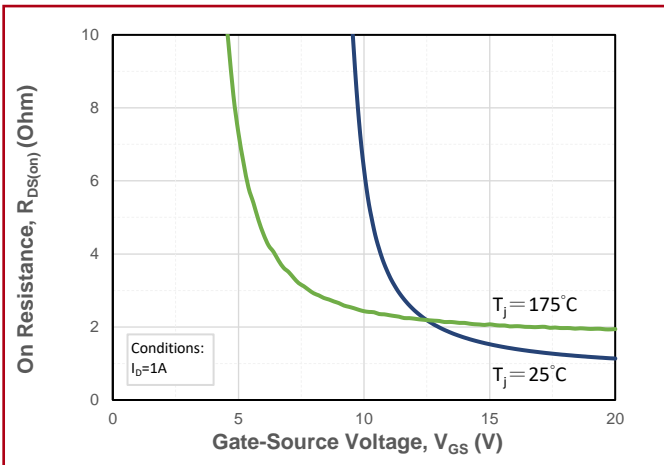

Fig.5 On-Resistance vs. Gate Voltage for Various T_j

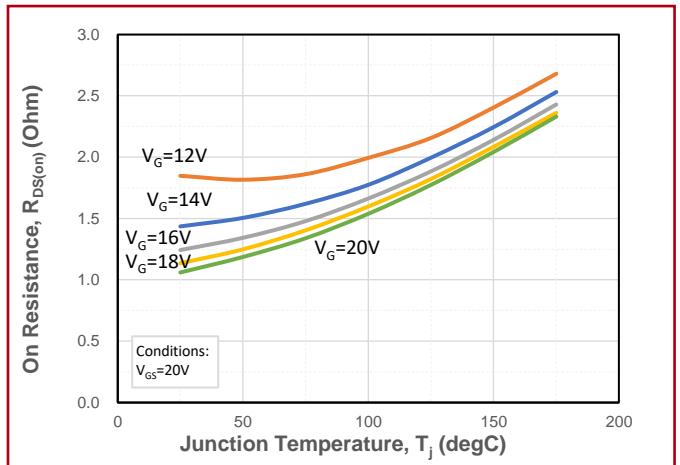

Fig.6 On-Resistance vs. Temperature for Various Gate Voltage

Typical Device Performance

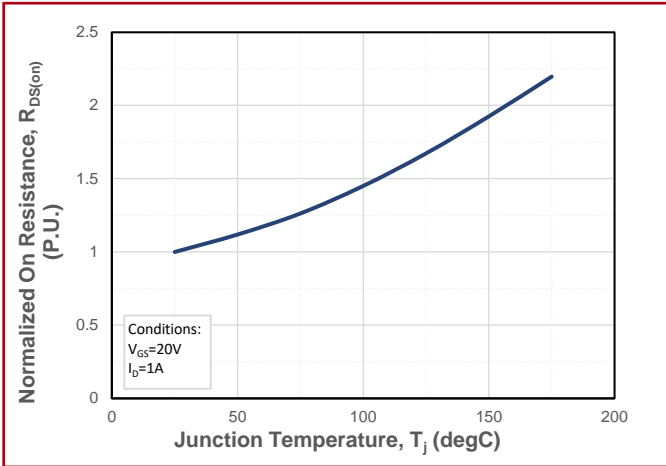

Fig.7 Normalized On-Resistance vs. Temperature

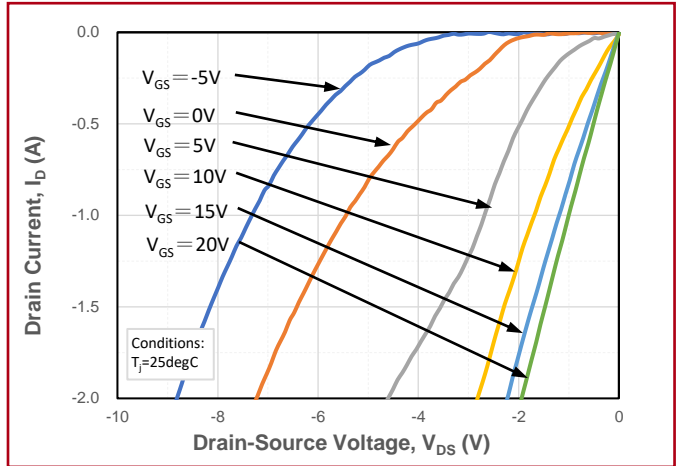

Fig.8 Reverse Output Characteristics at $T_j = 25^\circ C$

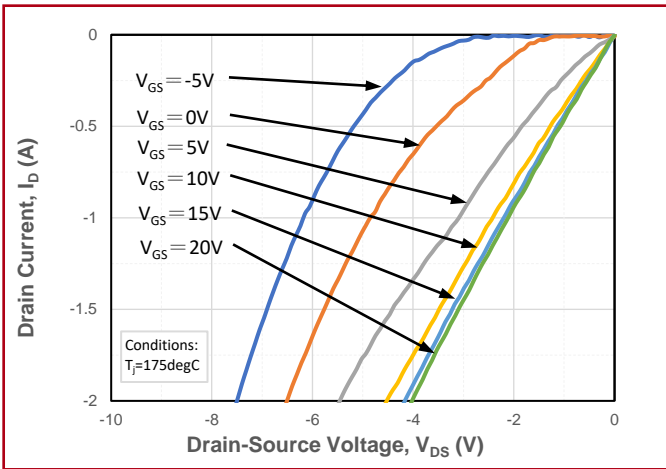

Fig.9 Reverse Output Characteristics at $T_j = 175^\circ C$

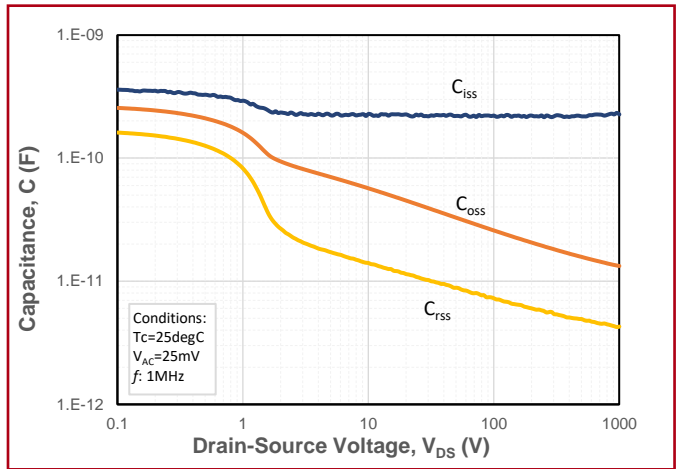

Fig.10 Capacitances vs. Drain to Source Voltage

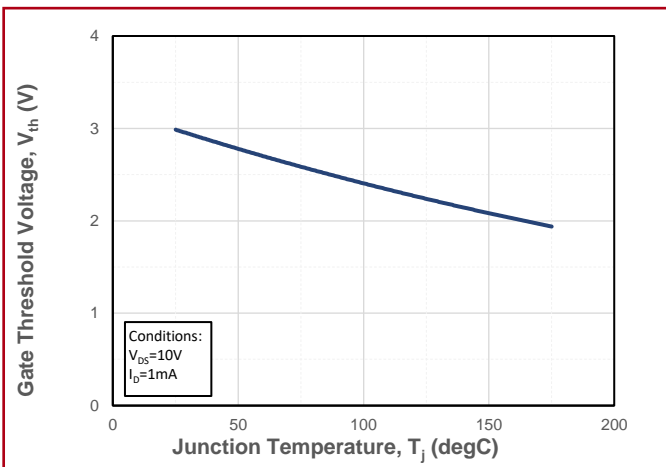

Fig.11 Threshold Voltage vs. Temperature

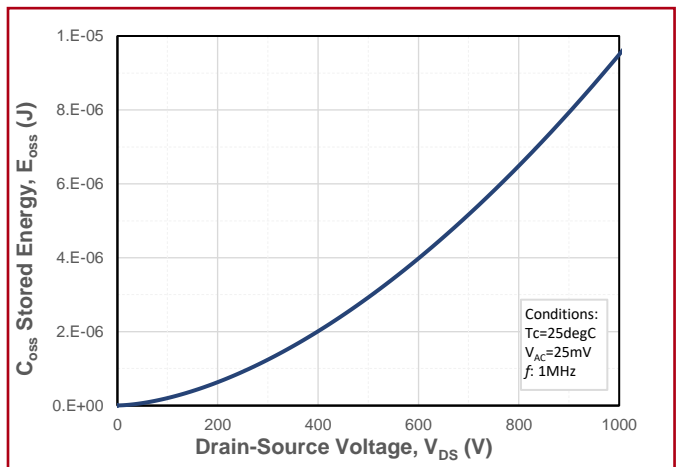

Fig.12 Output Capacitor Stored Energy

Typical Device Performance

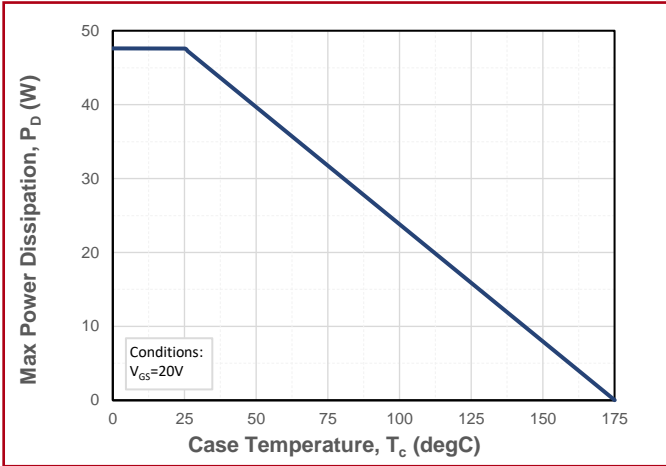

Fig.13 Maximum Power Dissipation Derating vs. Case Temperature

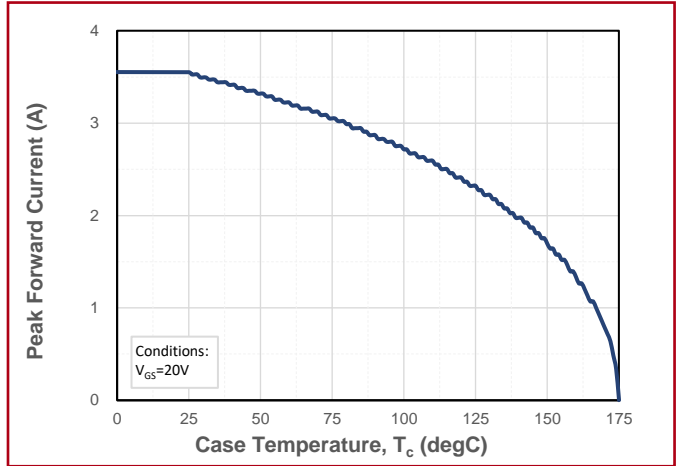

Fig.14 Drain Current Derating vs. Case Temperature

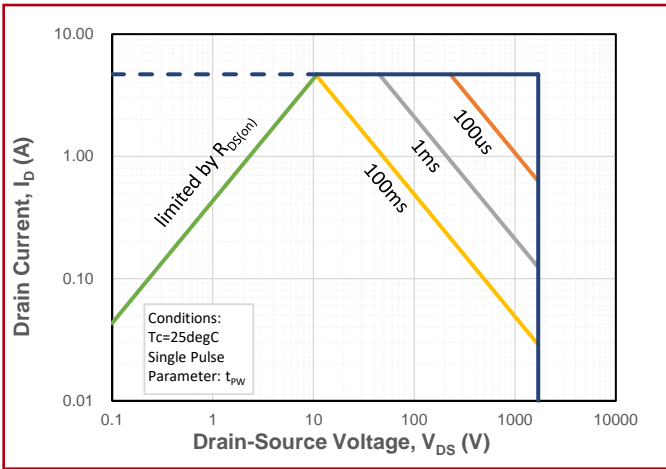

Fig.15 Safe Operating Area

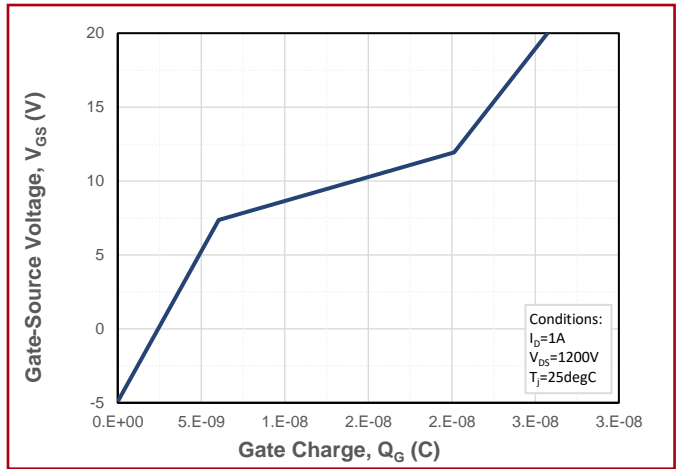

Fig.16 Gate Charge Characteristics

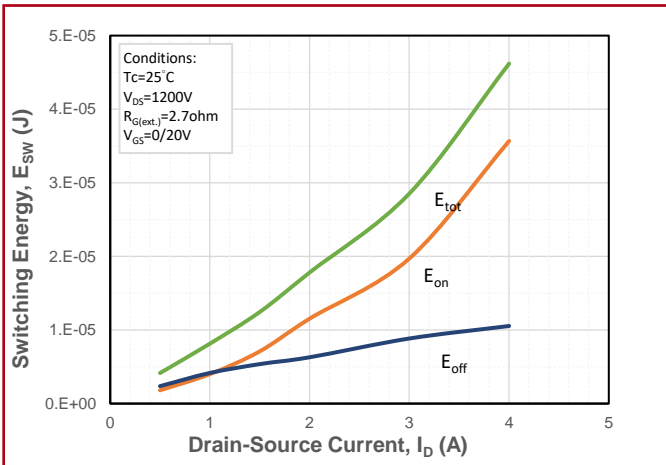

Fig.17 Clamped Inductive Switching Energy vs. Drain Current

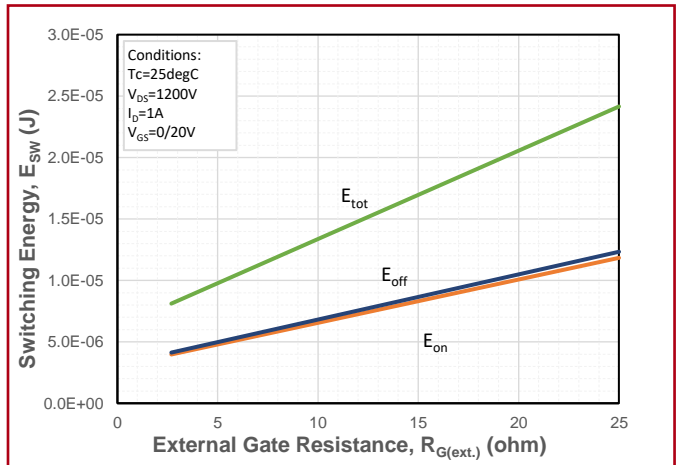

Fig.18 Clamped Inductive Switching Energy vs. External Gate Resistor ($R_{G(ext.)}$)

Typical Device Performance

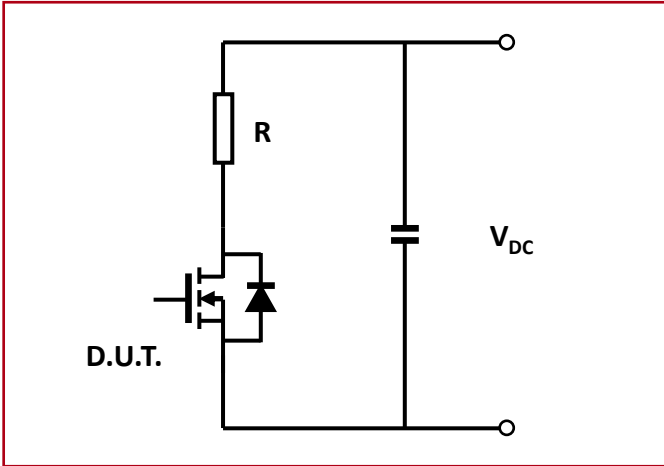

Fig.19 Schematic of Resistive Switching

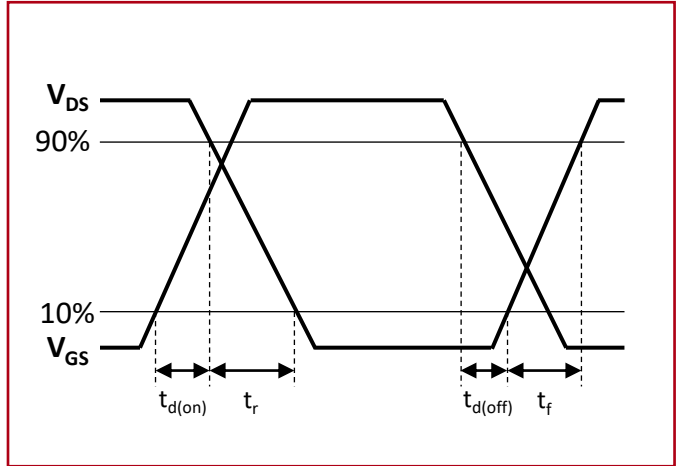

Fig.20 Switching Times Definition

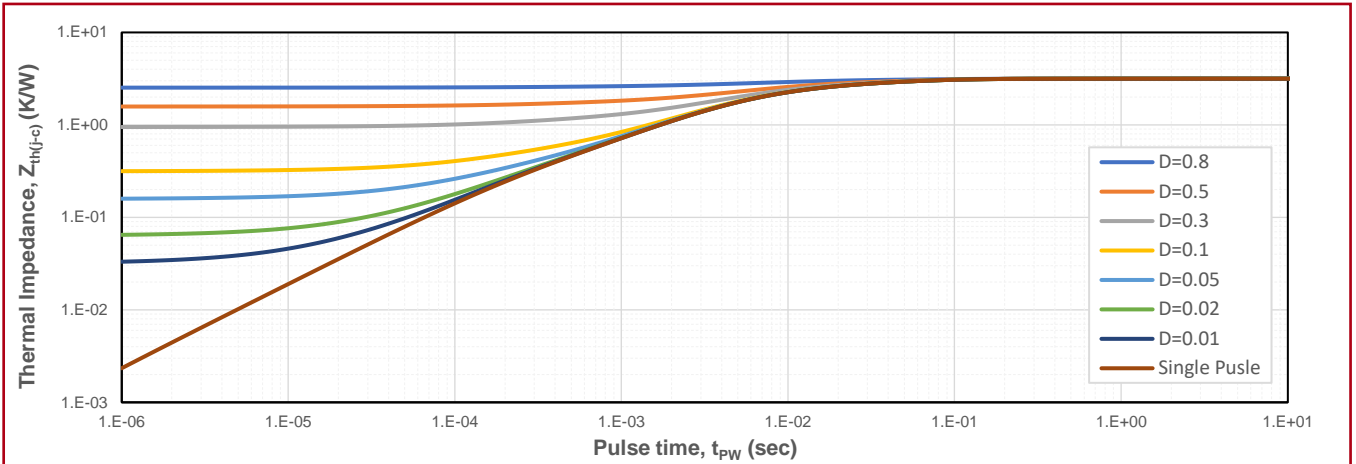

Fig.21 Transient Junction to Case Thermal Impedance

Naming Rule

H1 M 170 Q 1K2

Generation

H1 = 1st Gen Discrete

Device Type

M = MOSFET J = JMOS

S = JBS diode

Breakdown Voltage

065 = 650V 170 = 1700V

120 = 1200V 330 = 3300V

Package

Q = TO-247-4L B = TO-220-3L

T = TO-263-2L N = Bare Die

Typical On-Resistance

030 = 30mΩ 060 = 60mΩ 120 = 120mΩ

240 = 240mΩ 2K0 = 2Ω

Recommended Solder Pad Layout

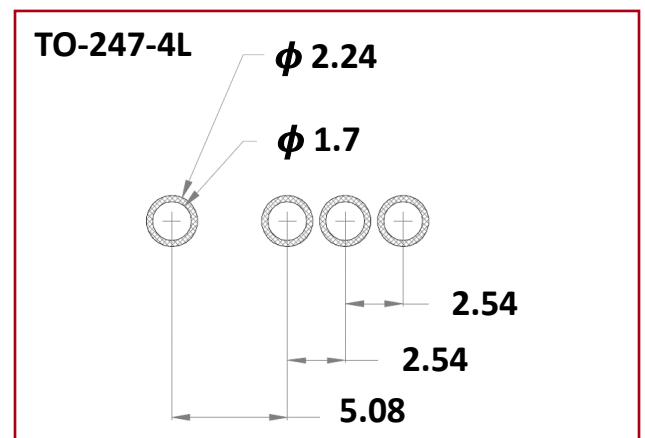

Package Dimensions

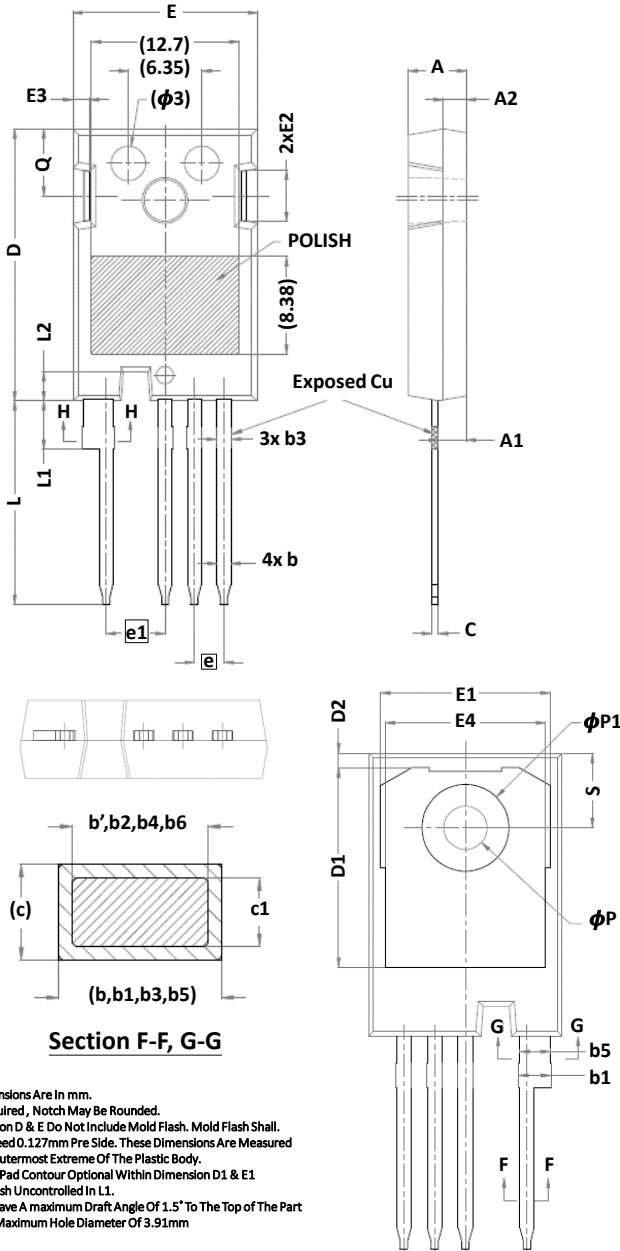

Note:
 1. All Dimensions Are In mm.
 2. Slot Required, Notch May Be Rounded.
 3. Dimension D & E Do Not Include Mold Flash. Mold Flash Shall Not Exceed 0.127mm Pre Side. These Dimensions Are Measured At The outermost Extreme Of The Plastic Body.
 4. Thermal Pad Contour Optional Within Dimension D1 & E1
 5. Lead Finish Uncontrolled In L1.
 6. φP To Have A maximum Draft Angle Of 1.5° To The Top Of The Part With A Maximum Hole Diameter Of 3.91mm

Symbol	mm		
	Min.	Typ.	Max.
A	4.83	5.02	5.21
A1	2.29	2.41	2.54
A2	1.91	2.00	2.16
b'	1.07	1.20	1.28
b	1.07	1.20	1.33
b1	2.39	2.67	2.94
b2	2.39	2.67	2.84
b3	1.07	1.30	1.60
b4	1.07	1.30	1.50
b5	2.39	2.53	2.69
b6	2.39	2.53	2.64
c	0.55	0.60	0.68
c1	0.55	0.60	0.65
D	23.30	23.45	23.60
D1	16.25	16.55	17.65
D2	0.95	1.19	1.25
E	15.75	15.94	16.13
E1	13.10	14.02	14.15
E2	3.68	4.40	5.10
E3	1.00	1.45	1.90
E4	12.38	13.26	13.43
e	2.54 BSC		
e1	5.08 BSC		
L	17.31	17.57	17.82
L1	3.97	4.19	4.37
L2	2.35	2.50	2.65
φP	3.51	3.61	3.65
φP1	7.19 REF.		
Q	5.49	5.79	6.00
S	6.04	6.17	6.30

Notes

- The information provided herein is subject to change without notice.
- For other information that does not show on this datasheet, please contact us for inquiry.