

H1M120F060

Silicon Carbide MOSFET
N-CHANNEL ENHANCEMENT MODE

Features

- Low On-Resistance and High Current Density
- Low Capacitance for High Frequency Operation
- Ultra-high Avalanche Ruggedness
- Positive Temperature Coefficient Device
- AEC-Q101 Qualified
- RoHS Compliant and Halogen Free

Benefits

- Higher System Efficiency
- Increase Parallel Device Convenience
- Capable of 175°C High T_j Application
- Allow High Frequency Operation
- Realize Compact and Lightweight Systems

Applications

- Switching Mode Power Supply
- DC/DC Converters, UPS, and PFC
- EV Charging Station
- Motor Drives
- Power Inverters
- Solar/Wind Renewable Energy

Absolute Maximum Ratings ($T_c = 25^\circ\text{C}$ unless otherwise specified)

Parameter	Symbol	Test Conditions	Value	Unit
Drain – Source Voltage	$V_{DS, max}$	$V_{GS}=0V, I_{DS}=100\mu A$	1200	V
Continuous Drain Current	I_D	$V_{GS}=20V, T_c=25^\circ\text{C}$	44.5	A
		$V_{GS}=20V, T_c=110^\circ\text{C}$	30.6	
Pulse Drain Current	$I_{D, pulse}$	t_{PW} limitation per Fig.15	90.5	
Avalanche energy, Single Pulse	E_{AS}	$V_{DD}=100V, I_D=10A$	1250	mJ
Power Dissipation	P_D	$T_c=25^\circ\text{C}$	250.0	W
Recommend Gate Source Voltage	$V_{GS, op}$	Static, recommended DC operating values	-5 to 20	V
Maximum Gate Source Voltage	$V_{GS, max}$	Transient operating limit (AC $f > 1\text{Hz}$, duty cycle $< 1\%$)	-10 to 25	
Junction & Storage Temperature	T_j, T_{stg}		-55 to 175	$^\circ\text{C}$
Soldering Temperature	T_L		260	
Mounting Torque	M_D	M3 or 6-32 screw	1.0	Nm

Thermal Resistance

Parameter	Symbol	Min.	Typ.	Max.	Unit
Thermal Resistance, Junction to Case	$R_{\theta, JC}$		0.6		$^\circ\text{C/W}$

Product Summary

V_{DS}	1200V
$I_D(@25^\circ\text{C})$	44.5A
$R_{DS(on)}$	60mΩ



Circuit Diagram

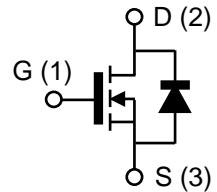
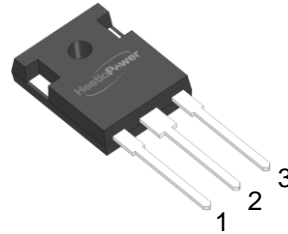

Part Number	Package	Marking
H1M120F060	TO-247-3L	H1M120F060

Description

The H1M120F060 1200V, 60mΩ silicon carbide power MOSFET is an N-channel enhancement mode device. Exploiting the outstanding wide bandgap material properties, this device shows high current density and great switching behavior. Thanks for the excellent thermal conductivity and many advantages of SiC, this device significantly improved in thermal capability and temperature independent switching behavior. With the high stability and reliability, this device also passes the qualification criteria based on AEC-Q101.

Electrical Characteristics (T_c = 25°C unless otherwise specified)

Parameter	Symbol	Test Conditions	Min.	Typ.	Max.	Unit
Drain-Source Breakdown Voltage	V _{(BR)DSS}	V _{GS} =0V, I _{DS} =100μA	1200			V
Gate Threshold Voltage	V _{GS(th)}	V _{DS} =10V, I _{DS} =20mA		2.85		V
Zero Gate Voltage Drain Current	I _{DSS}	V _{DS} =1200V, V _{GS} =0V		<1	50	μA
		V _{DS} =1200V, V _{GS} =0V T _j =175°C		10	500	
Gate-Source Leakage Current	I _{GSS}	V _{GS} =20V, V _{DS} =0V			250	nA
Drain-Source On-State Resistance	R _{DS(on)}	V _{GS} =20V, I _{DS} =20A		60	80	mΩ
		V _{GS} =20V, I _{DS} =20A, T _j =175°C		100		
Transconductance	g _{fs}	V _{DS} =12.5V, I _{DS} =40A		10.5		S
Input Capacitance	C _{iss}	V _{GS} =0V, V _{DS} =800V f=1MHz, V _{AC} =25mV		2200		pF
Output Capacitance	C _{oss}			115		
Reverse Transfer Capacitance	C _{rss}			18.5		
Effective Output Capacitance, Energy Related	C _{o(er)}		V _{GS} =0V, V _{DS} =0 to 800V		150	
Effective Output Capacitance, Time Related	C _{o(tr)}	I _D =const., V _{GS} =0V, V _{DS} =0 to 800V		211		
Turn On Delay Time	t _{d(on)}	V _{DS} =800V, V _{GS} =-4/20V, I _D =20A, R _L =40Ω, R _{G(ext)} = 2.7 Ω		25		ns
Rise Time	t _r			24		
Turn Off Delay Time	t _{d(off)}			20		
Fall Time	t _f			9		
C _{oss} Stored Energy	E _{oss}	V _{GS} =0V, V _{DS} =800V f=1MHz, V _{AC} =25mV		47		μJ
Turn-on Switching Energy	E _{on}	V _{DS} =800V, V _{GS} =0/20V, I _D =20A,		63*		
Turn-off Switching Energy	E _{off}	R _{G(ext)} = 2.7 Ω		69*		
Internal Gate Resistance	R _{G(int.)}	f=1MHz, V _{AC} =25mV		1.2		Ω

Built-in SiC Diode Characteristics (T_c = 25°C unless otherwise specified)

Parameter	Symbol	Test Conditions	Typ.	Unit
Inverse Diode Forward Voltage	V _{SD}	V _{GS} =0V, I _{SD} =5A	2.65	V
Continuous Diode Forward Current	I _S	V _{GS} =0V, T _c =25°C	44	A
Reverse Recovery Time	t _{rr}	V _{GS} =0V,	57	ns
Reverse Recovery Charge	Q _{rr}	I _{SD} =20A, V _{DS} =400V,	109	nC
Peak Reverse Recovery Current	I _{rrm}	di/dt=300A/μs	3.5	A

*Based on the results of calculation, note that the energy loss caused by the reverse recovery of free-wheeling diode is not included in E_{on}.

Gate Charge Characteristics (T_c = 25°C unless otherwise specified)

Parameter	Symbol	Test Conditions	Value	Unit
Gate to Source Charge	Q _{GS}	V _{DS} =800V, V _{GS} =-5/+20V, I _D =20A	29	nC
Gate to Drain Charge	Q _{GD}		64	
Total Gate Charge	Q _G		129	
Gate plateau voltage	V _{pl}		6.95	V

Typical Device Performance

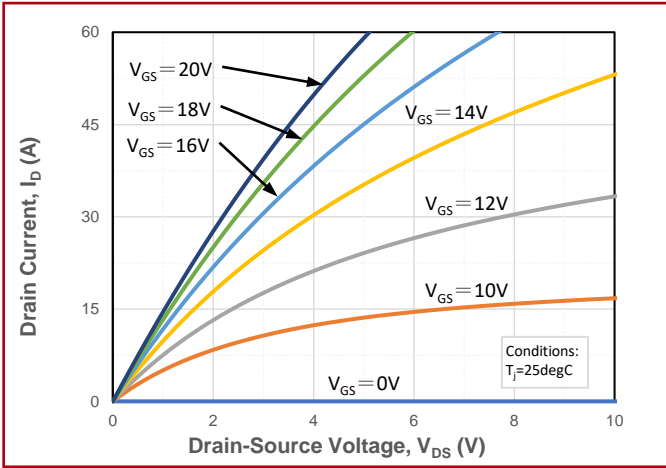

Fig.1 Forward Output Characteristics at $T_j = 25^\circ\text{C}$

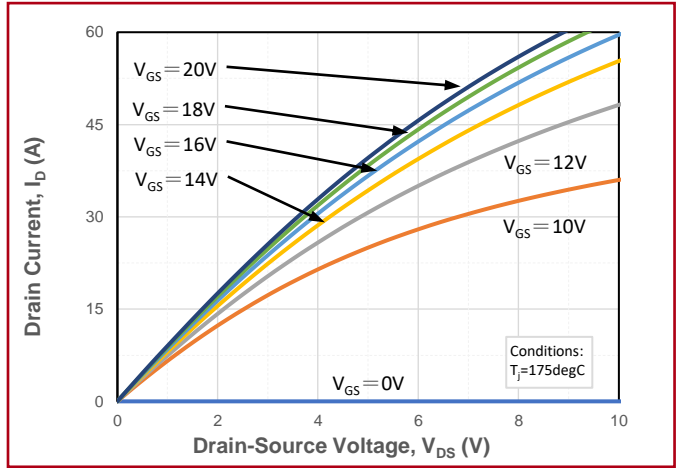

Fig.2 Forward Output Characteristics at $T_j = 175^\circ\text{C}$

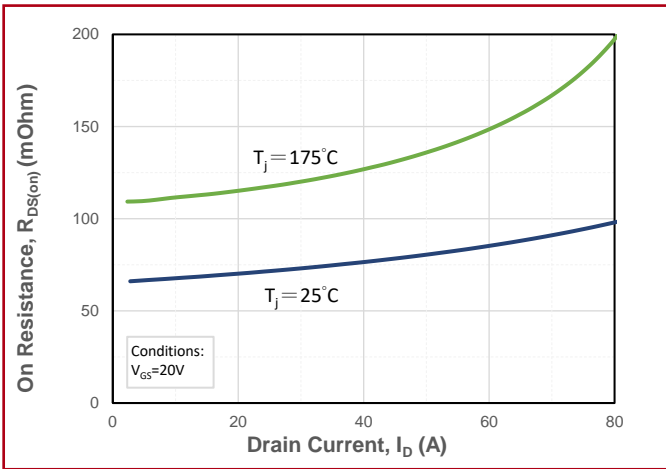

Fig.3 On-Resistance vs. Drain Current for Various T_j

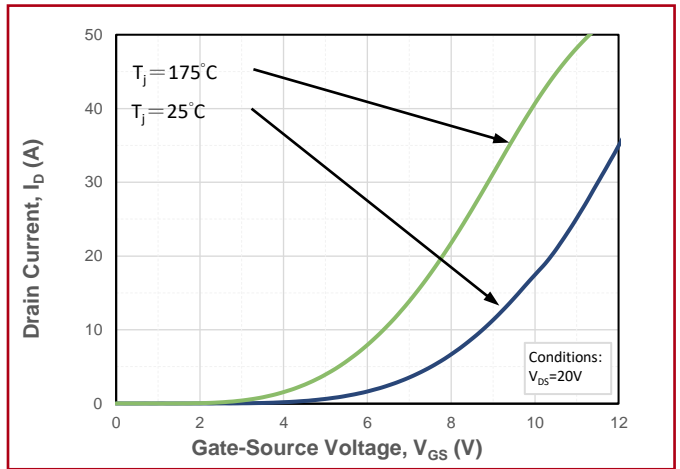

Fig.4 Transfer Characteristics for Various T_j

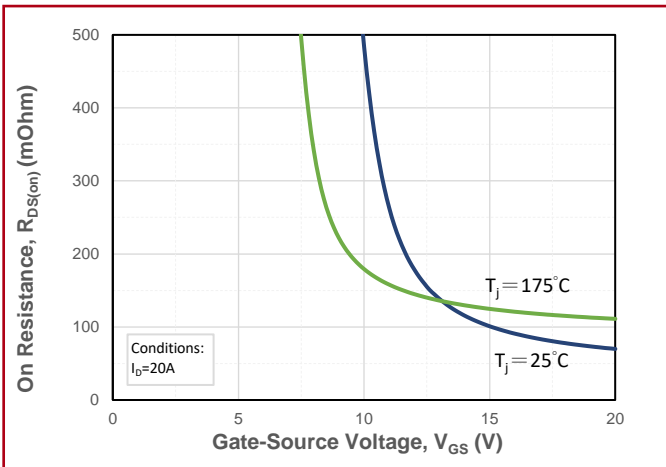

Fig.5 On-Resistance vs. Gate Voltage for Various T_j

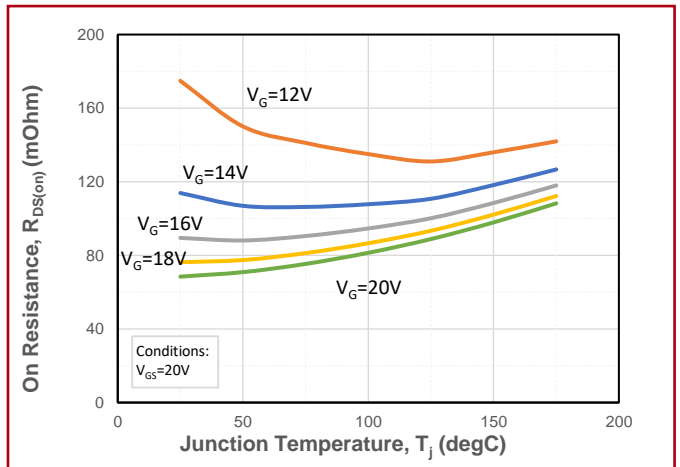

Fig.6 On-Resistance vs. Temperature for Various Gate Voltage

Typical Device Performance

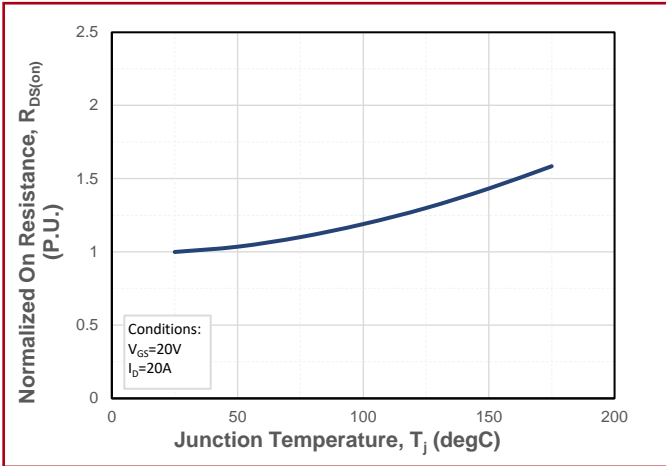

Fig.7 Normalized On-Resistance vs. Temperature

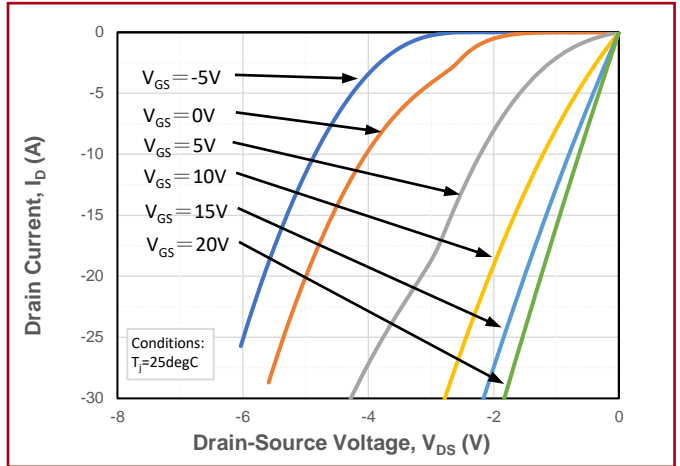

Fig.8 Reverse Output Characteristics at $T_j = 25^\circ C$

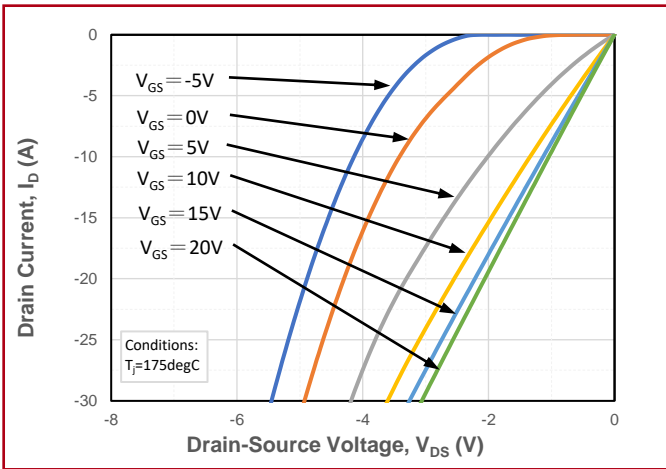

Fig.9 Reverse Output Characteristics at $T_j = 175^\circ C$

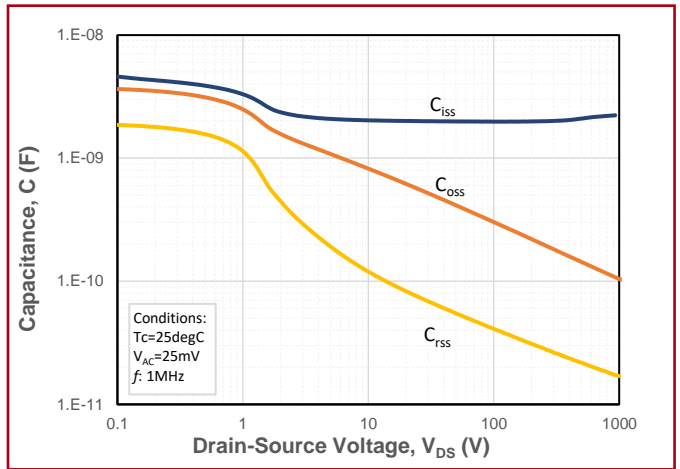

Fig.10 Capacitances vs. Drain to Source Voltage

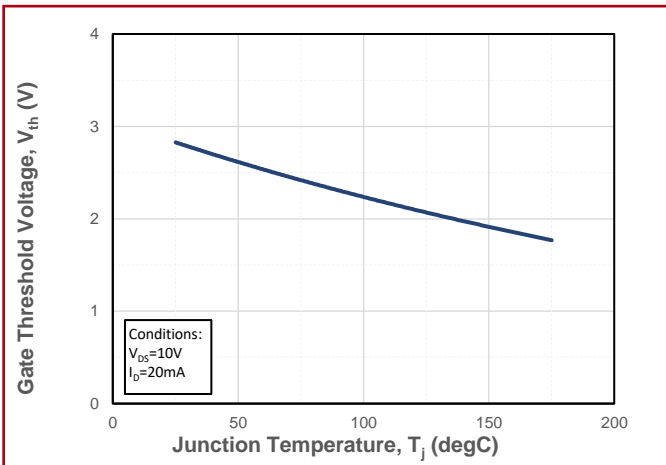

Fig.11 Threshold Voltage vs. Temperature

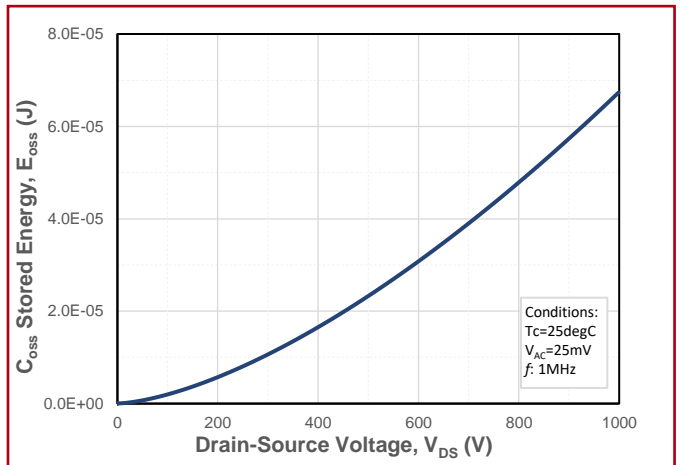

Fig.12 Output Capacitor Stored Energy

Typical Device Performance

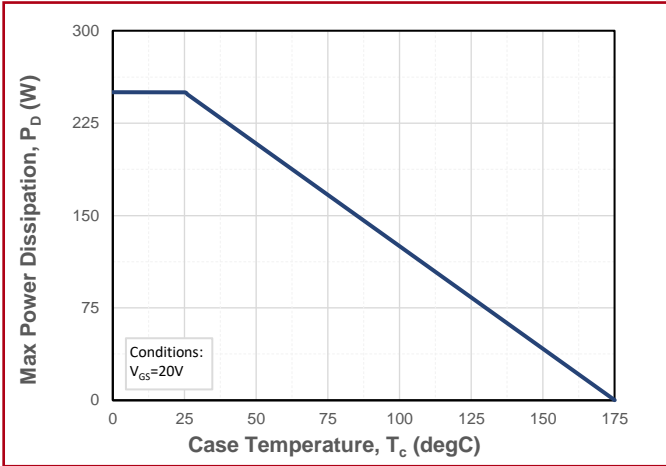

Fig.13 Maximum Power Dissipation Derating vs. Case Temperature

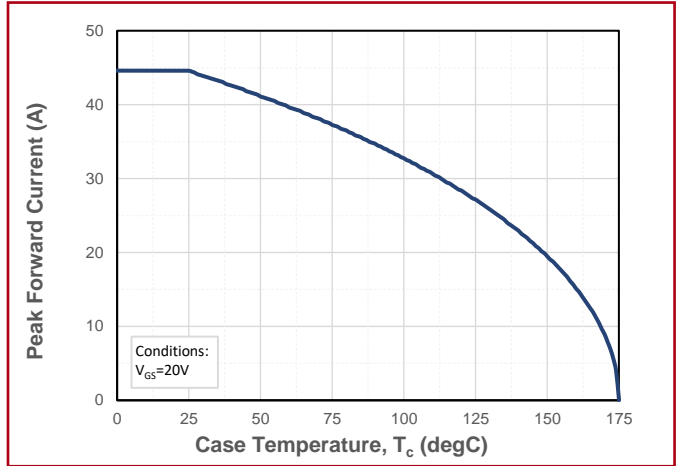

Fig.14 Drain Current Derating vs. Case Temperature

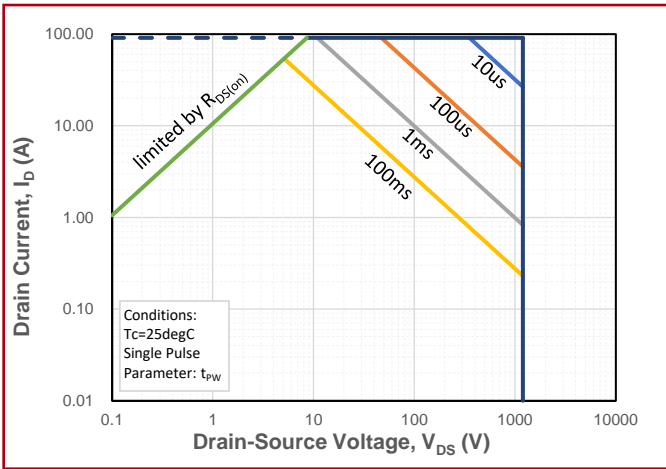

Fig.15 Safe Operating Area

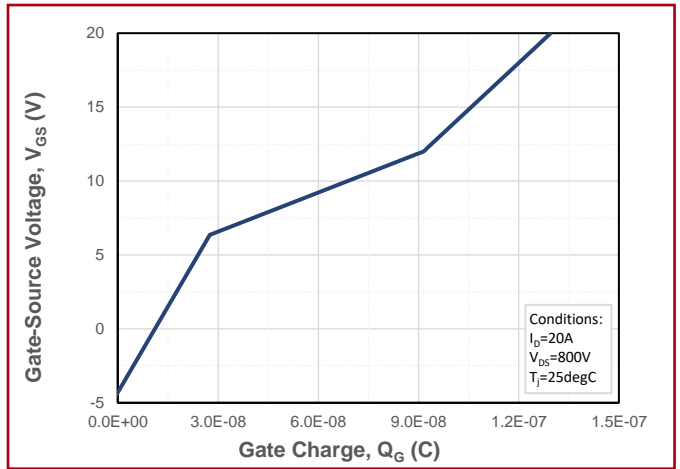

Fig.16 Gate Charge Characteristics

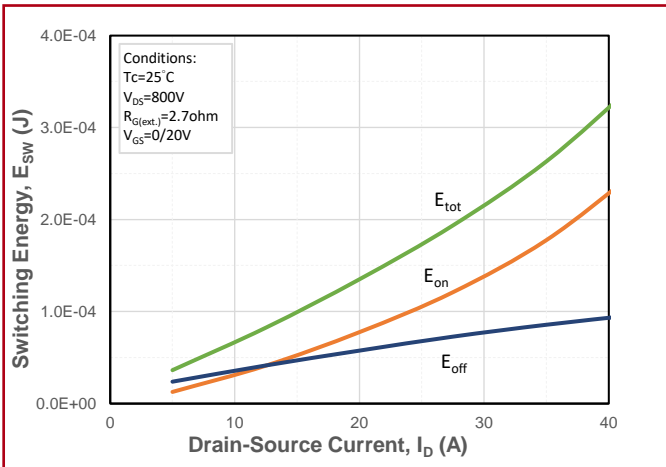

Fig.17 Clamped Inductive Switching Energy vs. Drain Current

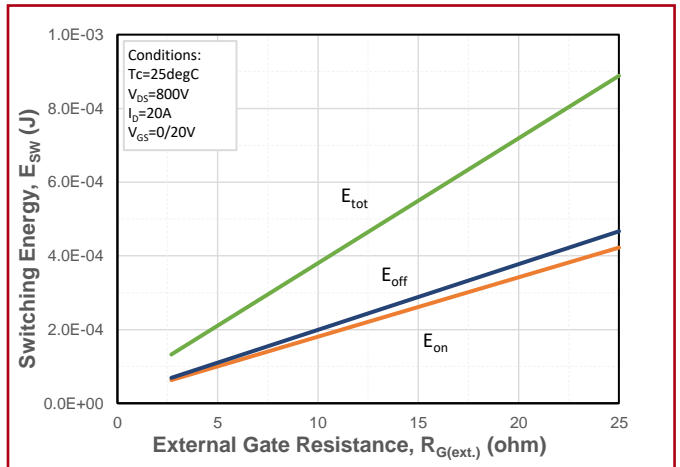

Fig.18 Clamped Inductive Switching Energy vs. External Gate Resistor ($R_{G(ext.)}$)

Typical Device Performance

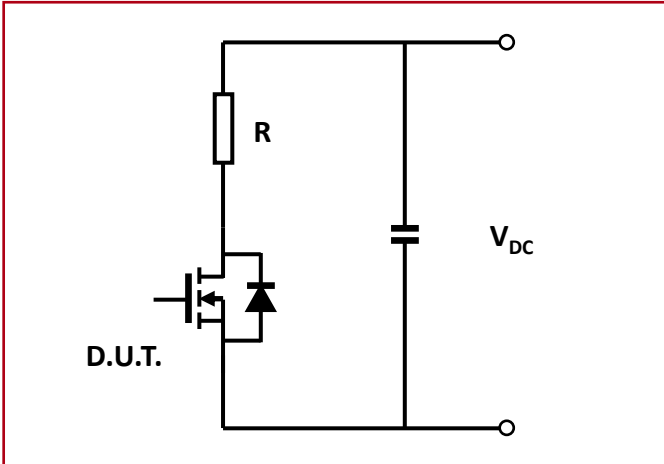

Fig.19 Schematic of Resistive Switching

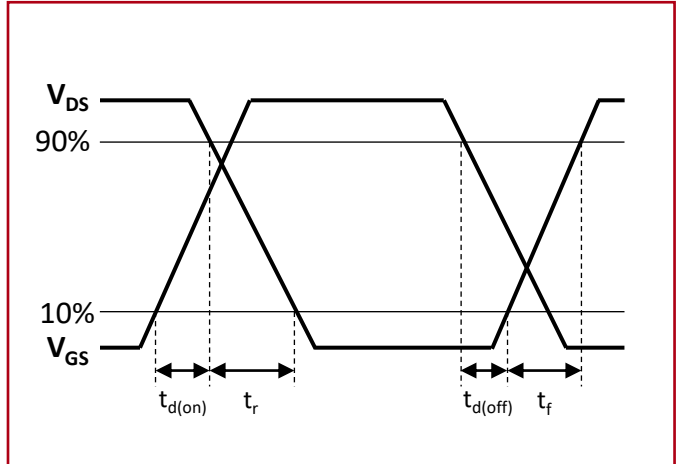

Fig.20 Switching Times Definition

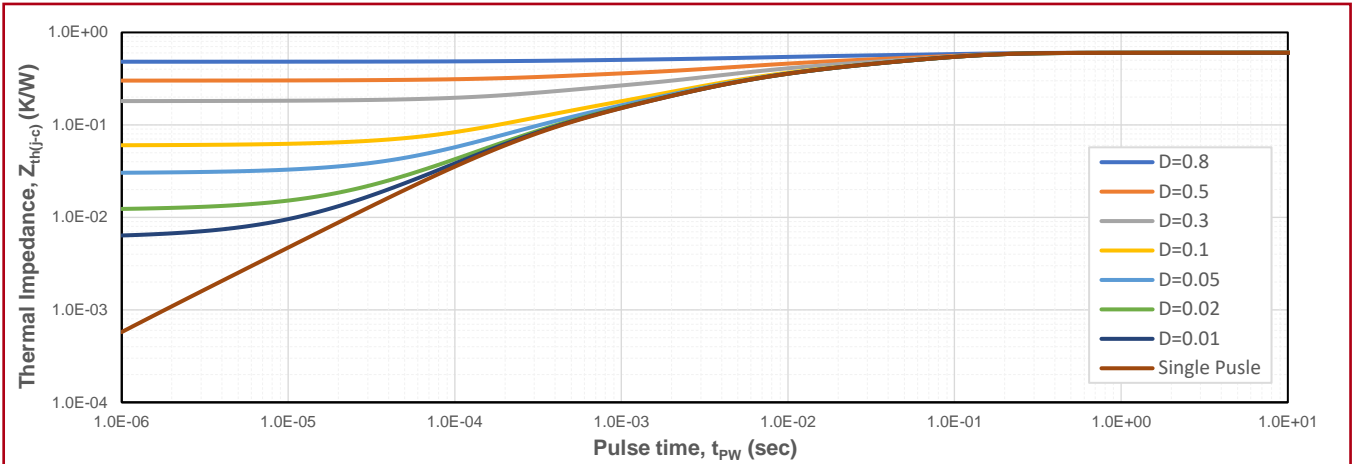

Fig.21 Transient Junction to Case Thermal Impedance

Naming Rule

H1 M 120 F 060

Generation

H1 = 1st Gen Discrete

Device Type

M = MOSFET J = JMOS

S = JBS diode

Breakdown Voltage

065 = 650V 170 = 1700V

120 = 1200V 330 = 3300V

Package

F = TO-247-3L B = TO-220-3L

T = TO-263-2L N = Bare Die

Typical On-Resistance

030 = 30mΩ 060 = 60mΩ 120 = 120mΩ

240 = 240mΩ

Recommended Solder Pad Layout

TO-247-3L

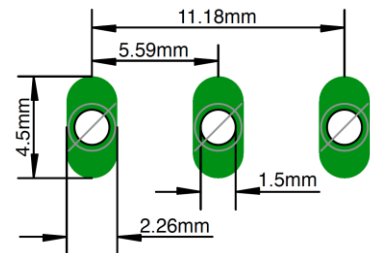

Package Dimensions

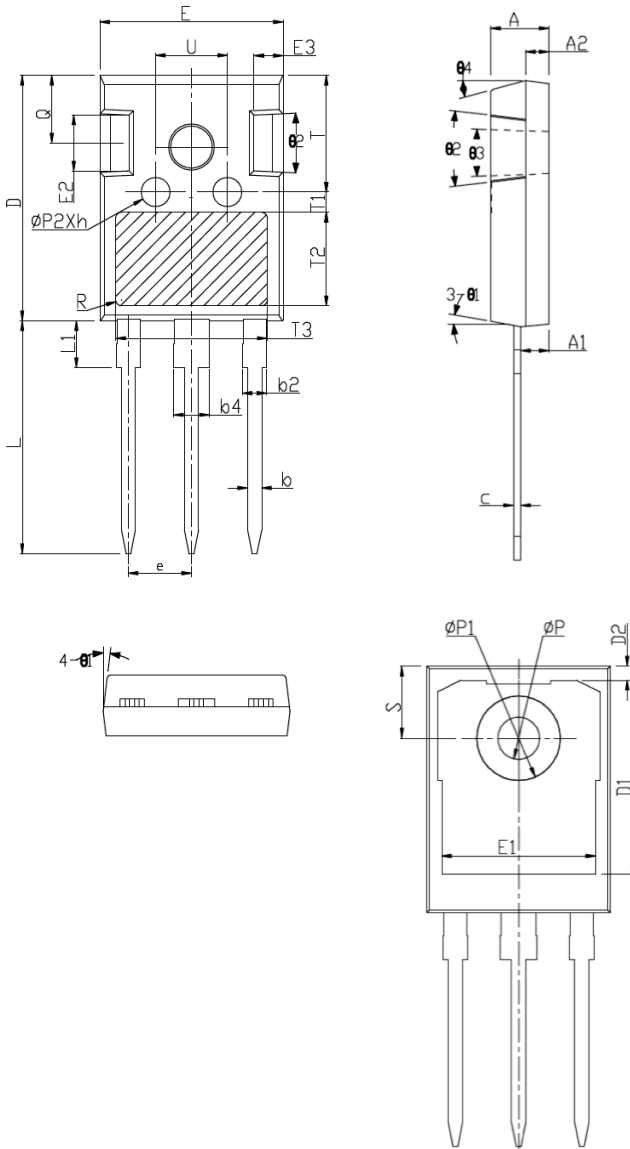

Symbol	mm		
	Min.	Typ.	Max.
A	4.75	5.00	5.25
A1	2.16	2.41	2.66
A2	1.85	2.00	2.15
b	1.11	1.21	1.35
b2	1.90	2.01	2.25
b4	2.90	3.01	3.25
c	0.51	0.61	0.75
D	20.60	21.00	21.40
D1	16.15	16.55	16.95
D2	1.00	1.20	1.40
E	15.50	15.80	16.10
E1	13.00	13.30	13.60
E2	4.70	5.00	5.30
E3	2.25	2.50	2.75
e	5.44 BSC		
h	0.00	0.10	0.25
L	19.52	19.92	20.32
L1	-	-	4.30
φP	3.35	3.60	3.85
φP1	-	-	7.30
φP2	2.25	2.50	2.75
Q	5.50	5.80	6.10
S	6.15 BSC		
R	0.50 REF		
T	9.70	-	10.30
T1	1.65 REF		
T2	8.00 REF		
T3	12.80 REF		
U	5.90	-	6.50
θ1	4°	7°	10°
θ2	2°	5°	8°
θ3	1°	-	2°
θ4	10°	15°	20°

Notes

- The information provided herein is subject to change without notice.
- For other information that does not show on this datasheet, please contact us for inquiry.