

# H1M065Q100

Silicon Carbide MOSFET  
N-CHANNEL ENHANCEMENT MODE

## Features

- Low On-Resistance and High Current Density
- Low Capacitance for High Frequency Operation
- Ultra-high Avalanche Ruggedness
- Positive Temperature Coefficient Device
- Low impedance Kelvin source pin-out
- RoHS Compliant and Halogen Free

## Benefits

- Higher System Efficiency
- Increase Parallel Device Convenience
- Capable of 175°C High  $T_j$  Application
- Allow High Frequency Operation
- Realize Compact and Lightweight Systems

## Applications

- Switching Mode Power Supply
- DC/DC Converters, UPS, and PFC
- EV Charging Station
- Motor Drives
- Power Inverters
- Solar/Wind Renewable Energy

## Absolute Maximum Ratings ( $T_c = 25^\circ\text{C}$ unless otherwise specified)

Parameter	Symbol	Test Conditions	Value	Unit
Drain – Source Voltage	$V_{DS, max}$	$V_{GS}=0V, I_{DS}=100\mu A$	650	V
Continuous Drain Current	$I_D$	$V_{GS}=20V, T_c=25^\circ\text{C}$	32	A
		$V_{GS}=20V, T_c=110^\circ\text{C}$	22	
Pulse Drain Current	$I_{D, pulse}$	$t_{PW}$ limitation per Fig.15	58.5	
Avalanche energy, Single Pulse	$E_{AS}$	$V_{DD}=100V, I_D=7A$	800	mJ
Power Dissipation	$P_D$	$T_c=25^\circ\text{C}$	166	W
Recommend Gate Source Voltage	$V_{GS, op}$	Static, recommended DC operating values	-5 to 20	V
Maximum Gate Source Voltage	$V_{GS, max}$	Transient operating limit (AC $f > 1\text{Hz}$ , duty cycle $< 1\%$ )	-10 to 25	
Junction & Storage Temperature	$T_j, T_{stg}$		-55 to 175	$^\circ\text{C}$
Soldering Temperature	$T_L$		260	
Mounting Torque	$M_D$	M3 or 6-32 screw	1.0	Nm

## Thermal Resistance

Parameter	Symbol	Min.	Typ.	Max.	Unit
Thermal Resistance, Junction to Case	$R_{\theta, jC}$		0.9		$^\circ\text{C/W}$

## Product Summary

$V_{DS}$	650V
$I_D(@25^\circ\text{C})$	32A
$R_{DS(on)}$	100mΩ



## Circuit Diagram

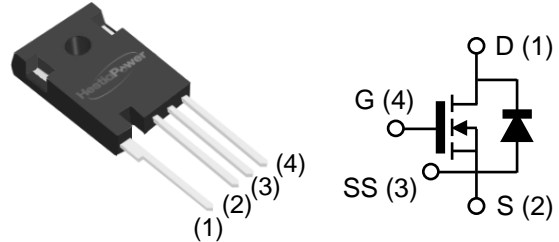

Part Number	Package	Marking
H1M065Q100	TO-247-4L	H1M065Q100

## Description

The H1M065Q100 650V, 100mΩ silicon carbide power MOSFET is an N-channel enhancement mode device. Exploiting the outstanding wide bandgap material properties, this device shows high current density and great switching behavior. Thanks for the excellent thermal conductivity and many advantages of SiC, this device significantly improved in thermal capability and temperature independent switching behavior.

**Electrical Characteristics** ( $T_c = 25^\circ\text{C}$  unless otherwise specified)

Parameter	Symbol	Test Conditions	Min.	Typ.	Max.	Unit
Drain-Source Breakdown Voltage	$V_{(BR)DSS}$	$V_{GS}=0V, I_{DS}=100\mu A$	650			V
Gate Threshold Voltage	$V_{GS(th)}$	$V_{DS}=10V, I_{DS}=10mA$		2.6		V
Zero Gate Voltage Drain Current	$I_{DSS}$	$V_{DS}=650V, V_{GS}=0V$		<1	50	$\mu A$
		$V_{DS}=650V, V_{GS}=0V$ $T_j=175^\circ\text{C}$		5	500	
Gate-Source Leakage Current	$I_{GSS}$	$V_{GS}=20V, V_{DS}=0V$			250	nA
Drain-Source On-State Resistance	$R_{DS(on)}$	$V_{GS}=20V, I_{DS}=12A$		100	130	mΩ
		$V_{GS}=20V, I_{DS}=12A$ , $T_j=175^\circ\text{C}$		130		
Transconductance	$g_{fs}$	$V_{DS}=15V, I_{DS}=25A$		8.5		S
Input Capacitance	$C_{iss}$	$V_{GS}=0V, V_{DS}=400V$ $f=1MHz, V_{AC}=25mV$		910		pF
Output Capacitance	$C_{oss}$			105		
Reverse Transfer Capacitance	$C_{rss}$			13		
Effective Output Capacitance, Energy Related	$C_{o(er)}$		$V_{GS}=0V$ , $V_{DS}=0$ to 400V		130	
Effective Output Capacitance, Time Related	$C_{o(tr)}$	$I_D=const.$ , $V_{GS}=0V$ , $V_{DS}=0$ to 400V		177		
Short-Circuit Withstand Time	$t_{SC}$	$V_{GS}=0/15V, V_{DS}=400V$ $R_G=100\Omega$		<18		$\mu s$
Turn On Delay Time	$t_{d(on)}$	$V_{DS}=400V, V_{GS}=-4/+20V$ , $I_D=10A, R_L=40\Omega$ , $R_{G(ext)}=8.2\Omega$		15		ns
Rise Time	$t_r$			17		
Turn Off Delay Time	$t_{d(off)}$			15		
Fall Time	$t_f$			15		
$C_{oss}$ Stored Energy	$E_{oss}$	$V_{GS}=0V, V_{DS}=400V$ $f=1MHz, V_{AC}=25mV$		10		$\mu J$
Turn-on Switching Energy	$E_{on}$	$V_{DS}=400V, V_{GS}=0/20V$ , $I_D=12A$ ,		6.2*		
Turn-off Switching Energy	$E_{off}$	$R_{G(ext)}=2.7\Omega$		9.1*		
Internal Gate Resistance	$R_{G(int.)}$	$f=1MHz, V_{AC}=25mV$		2		$\Omega$

\*Based on the results of calculation, note that the energy loss caused by the reverse recovery of free-wheeling diode is not included in  $E_{on}$ .

**Built-in SiC Diode Characteristics** ( $T_c = 25^\circ\text{C}$  unless otherwise specified)

Parameter	Symbol	Test Conditions	Typ.	Unit
Inverse Diode Forward Voltage	$V_{SD}$	$V_{GS}=0V, I_{SD}=3A$	3.3	V
Continuous Diode Forward Current	$I_S$	$V_{GS}=0V, T_c=25^\circ\text{C}$	26.5	A
Reverse Recovery Time	$t_{rr}$	$V_{GS}=0V$ ,	54	ns
Reverse Recovery Charge	$Q_{rr}$	$I_{SD}=12A, V_{DS}=400V$ ,	72	nC
Peak Reverse Recovery Current	$I_{rrm}$	$di/dt=300A/\mu s$	2.57	A

**Gate Charge Characteristics** ( $T_c = 25^\circ\text{C}$  unless otherwise specified)

Parameter	Symbol	Test Conditions	Value	Unit
Gate to Source Charge	$Q_{GS}$	$V_{DS}=400V$ , $V_{GS}=-5/+20V$ , $I_D=12A$	13.5	nC
Gate to Drain Charge	$Q_{GD}$		34	
Total Gate Charge	$Q_G$		66	
Gate plateau voltage	$V_{pl}$		8.1	V

### Typical Device Performance

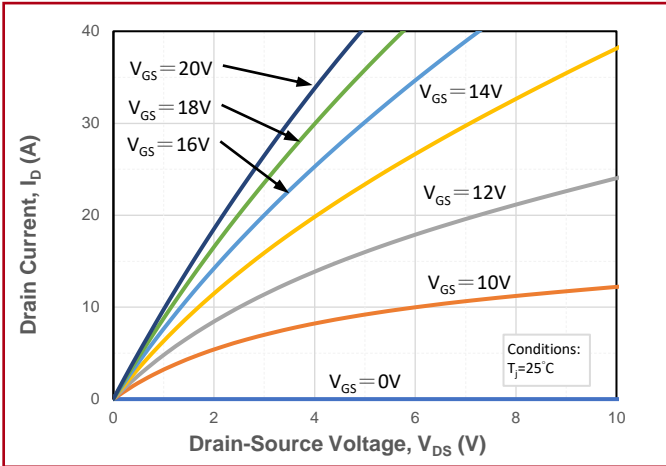

Fig.1 Forward Output Characteristics at  $T_j = 25^\circ\text{C}$

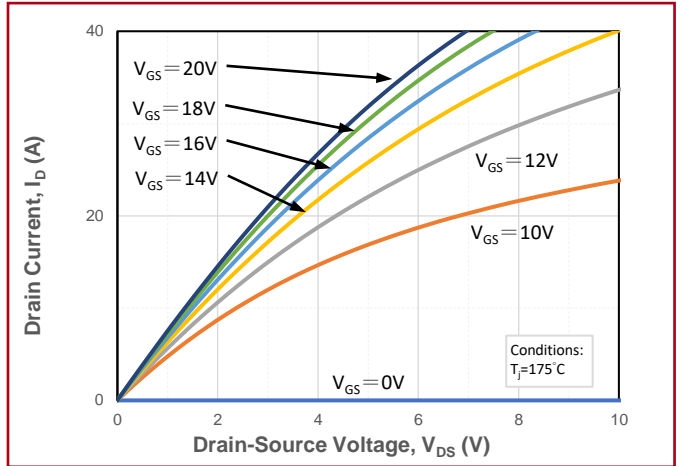

Fig.2 Forward Output Characteristics at  $T_j = 175^\circ\text{C}$

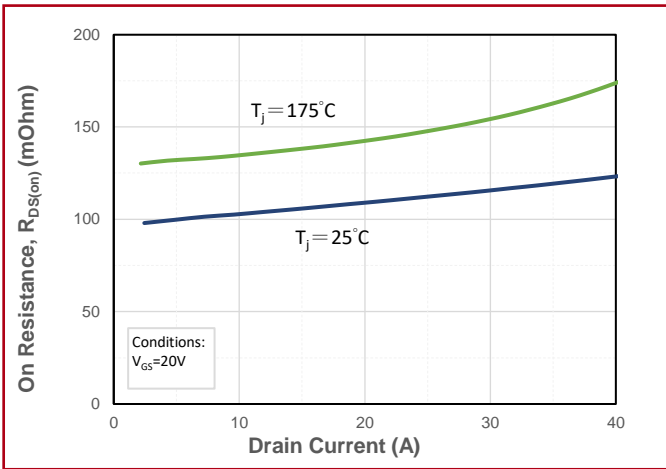

Fig.3 On-Resistance vs. Drain Current for Various  $T_j$

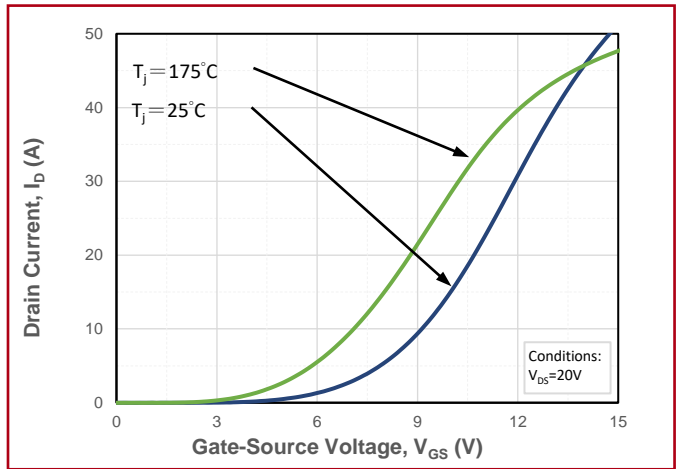

Fig.4 Transfer Characteristics for Various  $T_j$

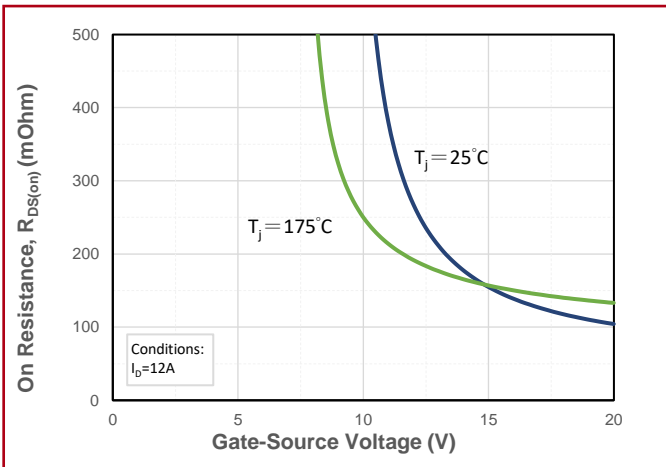

Fig.5 On-Resistance vs. Gate Voltage for Various  $T_j$

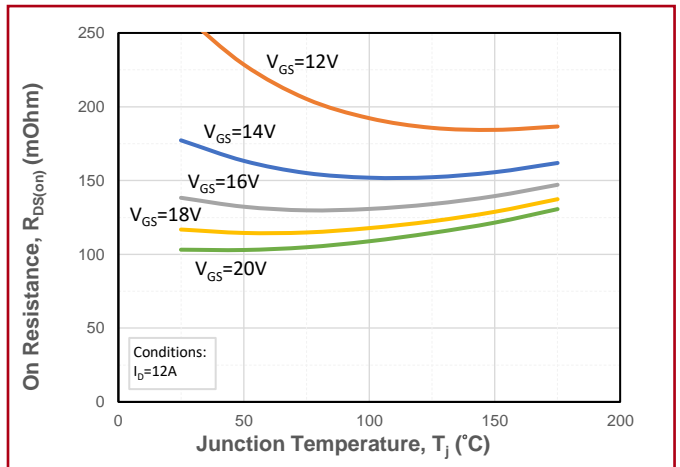
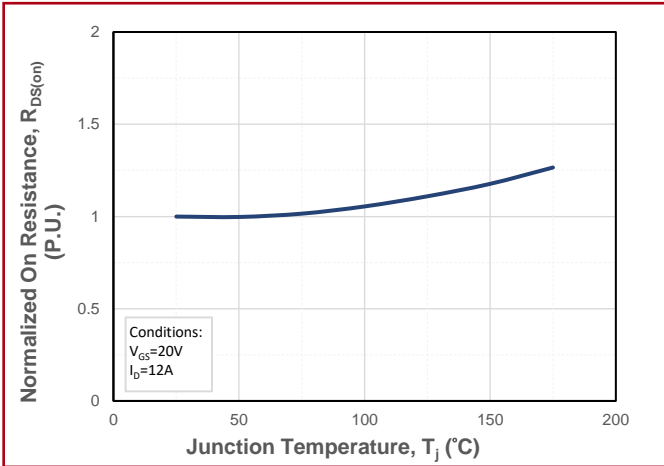
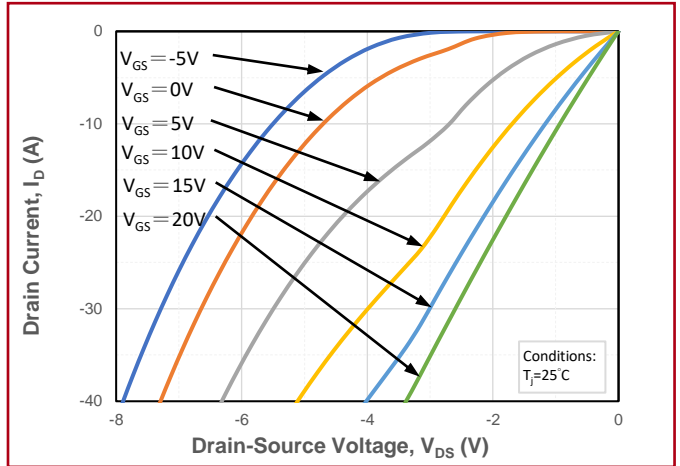

Fig.6 On-Resistance vs. Temperature for Various Gate Voltage

## Typical Device Performance



**Fig.7** Normalized On-Resistance vs. Temperature



**Fig.8** Reverse Output Characteristics at  $T_j = 25^\circ C$

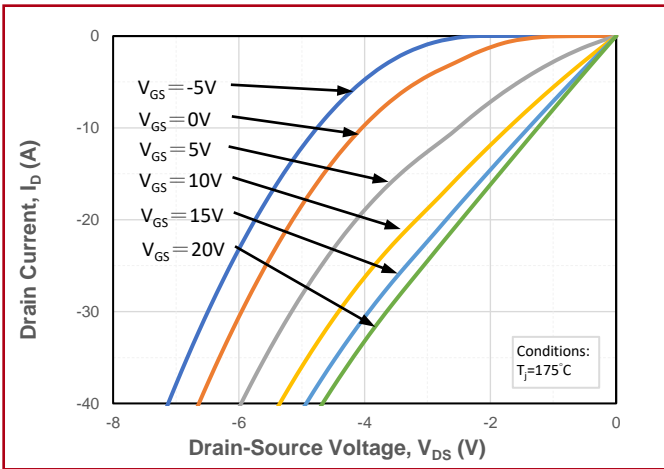

**Fig.9** Reverse Output Characteristics at  $T_j = 175^\circ C$

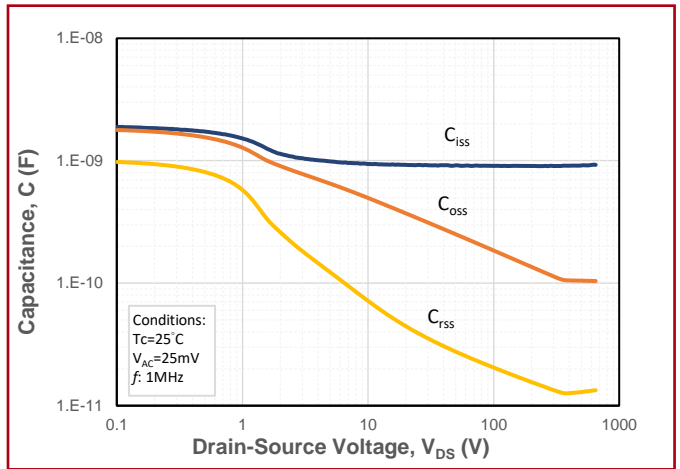

**Fig.10** Capacitances vs. Drain to Source Voltage

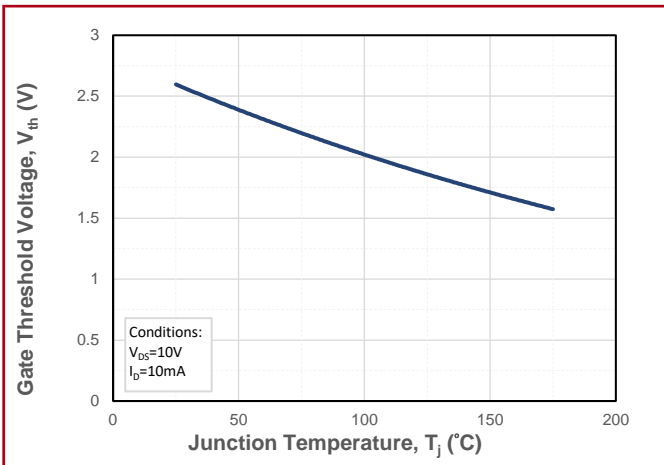

**Fig.11** Threshold Voltage vs. Temperature

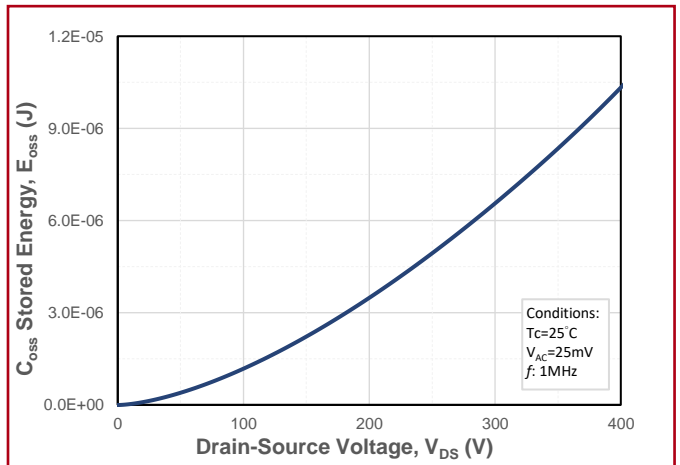

**Fig.12** Output Capacitor Stored Energy

## Typical Device Performance

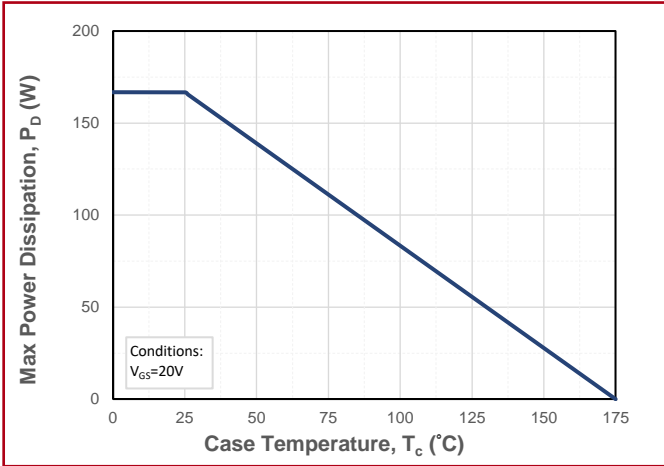

Fig.13 Maximum Power Dissipation Derating vs. Case Temperature

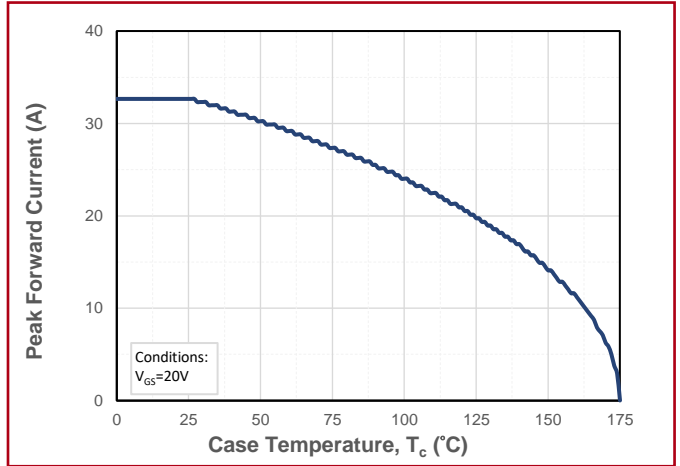

Fig.14 Drain Current Derating vs. Case Temperature

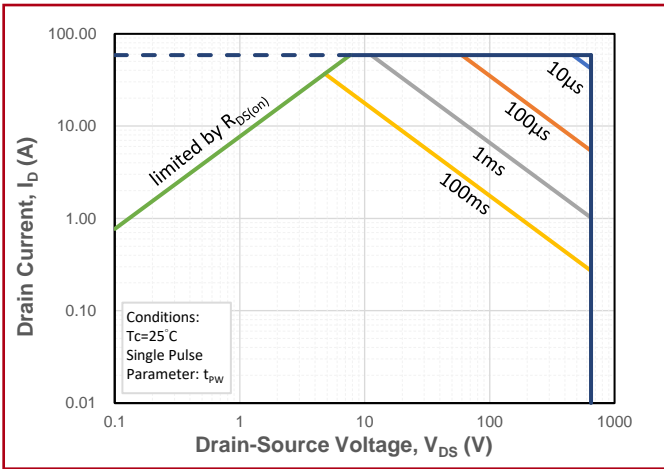

Fig.15 Safe Operating Area

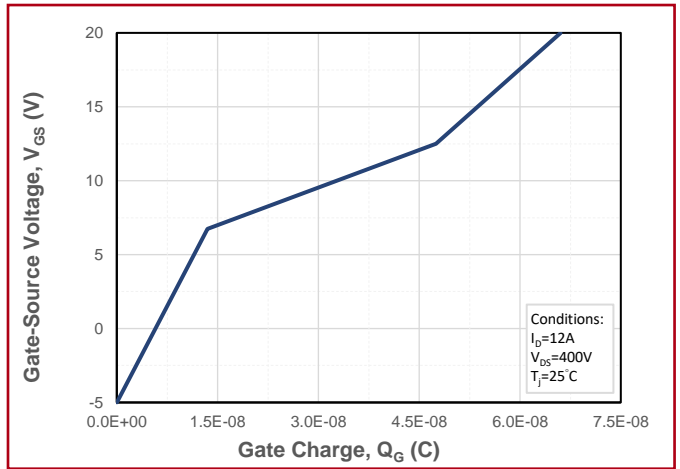

Fig.16 Gate Charge Characteristics

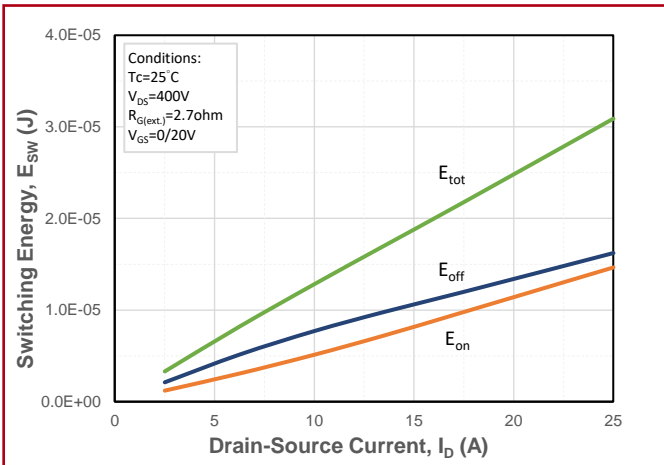

Fig.17 Clamped Inductive Switching Energy vs. Drain Current

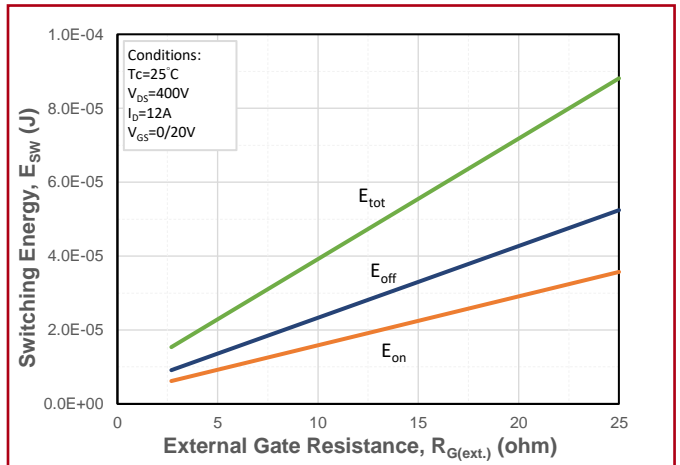

Fig.18 Clamped Inductive Switching Energy vs. External Gate Resistor ( $R_{G(ext.)}$ )

## Typical Device Performance

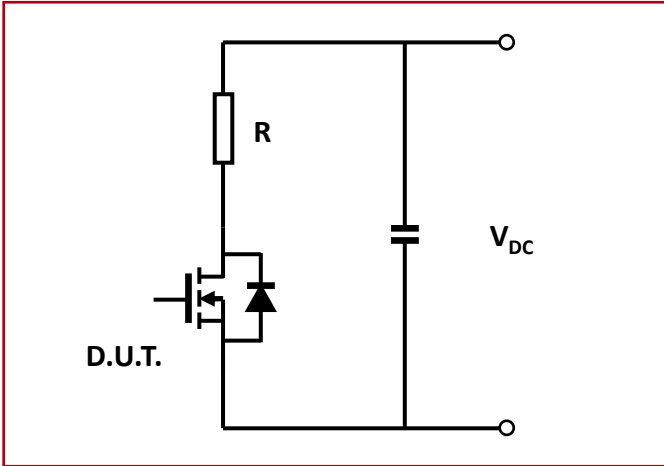

Fig.19 Schematic of Resistive Switching

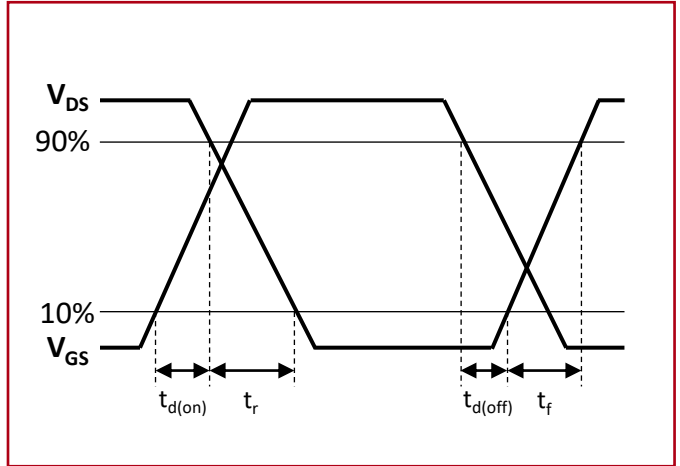

Fig.20 Switching Times Definition

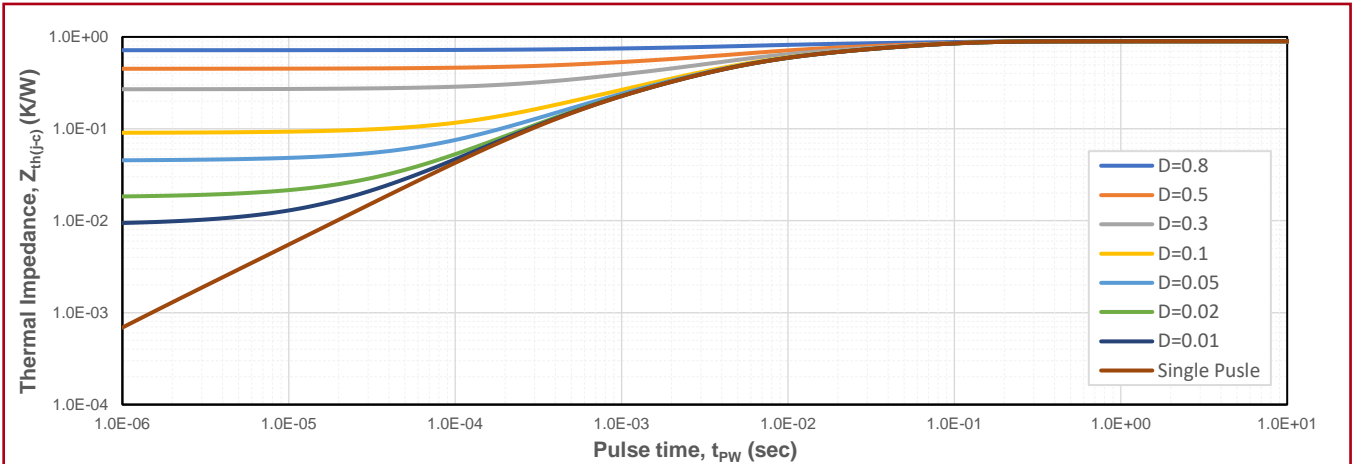

Fig.21 Transient Junction to Case Thermal Impedance

### Naming Rule

**H1 M 065 Q 100**

#### Generation

H1 = 1<sup>st</sup> Gen Discrete

#### Device Type

M = MOSFET    J = JMOS

S = JBS diode

#### Breakdown Voltage

065 = 650V    170 = 1700V

120 = 1200V    330 = 3300V

#### Package

Q = TO-247-4L    B = TO-220-3L

T = TO-263-2L    N = Bare Die

#### Typical On-Resistance

020 = 20mΩ    050 = 50mΩ    100 = 100mΩ

200 = 200mΩ

### Recommended Solder Pad Layout

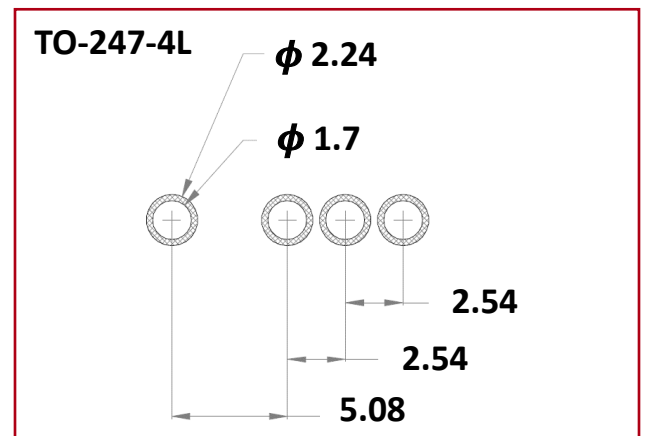

## Package Dimensions

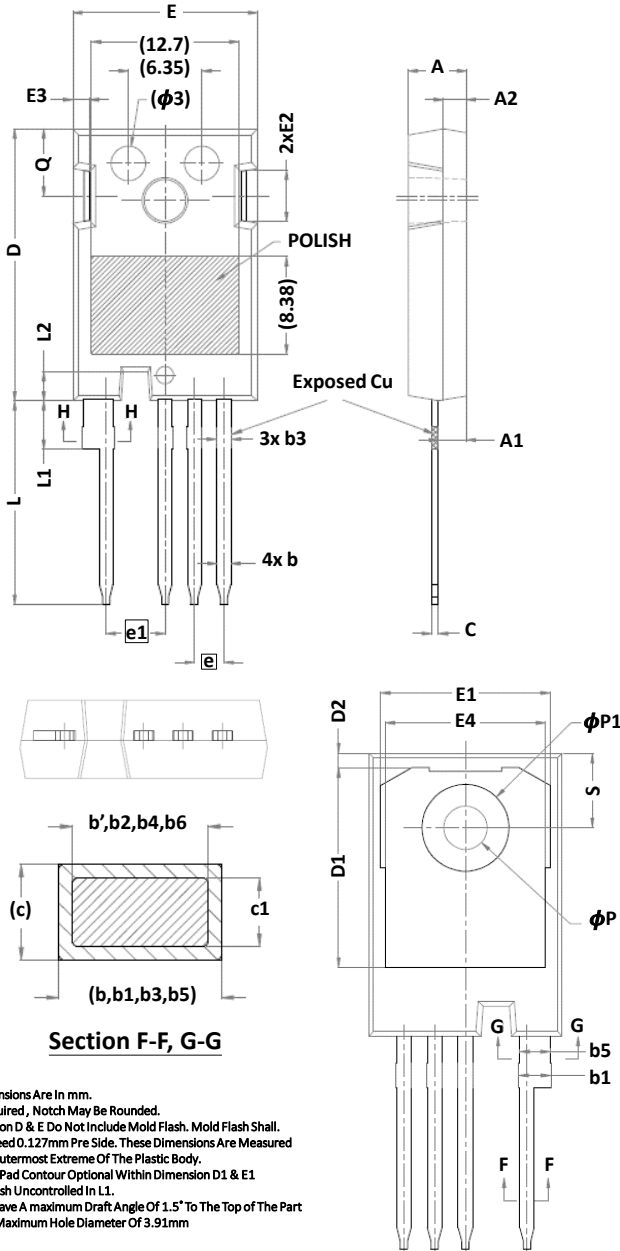

- Note:
- All Dimensions Are In mm.
  - Slot Required, Notch May Be Rounded.
  - Dimension D & E Do Not Include Mold Flash. Mold Flash Shall Not Exceed 0.127mm Pre Side. These Dimensions Are Measured At The outermost Extreme Of The Plastic Body.
  - Thermal Pad Contour Optional Within Dimension D1 & E1
  - Lead Finish Uncontrolled In L1.
  - $\phi P$  To Have A maximum Draft Angle Of 1.5° To The Top Of The Part With A Maximum Hole Diameter Of 3.91mm

Symbol	mm		
	Min.	Typ.	Max.
A	4.83	5.02	5.21
A1	2.29	2.41	2.54
A2	1.91	2.00	2.16
b'	1.07	1.20	1.28
b	1.07	1.20	1.33
b1	2.39	2.67	2.94
b2	2.39	2.67	2.84
b3	1.07	1.30	1.60
b4	1.07	1.30	1.50
b5	2.39	2.53	2.69
b6	2.39	2.53	2.64
c	0.55	0.60	0.68
c1	0.55	0.60	0.65
D	23.30	23.45	23.60
D1	16.25	16.55	17.65
D2	0.95	1.19	1.25
E	15.75	15.94	16.13
E1	13.10	14.02	14.15
E2	3.68	4.40	5.10
E3	1.00	1.45	1.90
E4	12.38	13.26	13.43
e	2.54 BSC		
e1	5.08 BSC		
L	17.31	17.57	17.82
L1	3.97	4.19	4.37
L2	2.35	2.50	2.65
$\phi P$	3.51	3.61	3.65
$\phi P1$	7.19 REF.		
Q	5.49	5.79	6.00
S	6.04	6.17	6.30

## Notes

- The information provided herein is subject to change without notice.
- For other information that does not show on this datasheet, please contact us for inquiry.