

Product Summary

V_R	1200V
$I_{F(135/154^\circ\text{C})}$	15A/10A
Q_C	56nC



H3S120A010, H3S120T010, H3S120U010

Features

- Low Conduction and Switching Loss
- Zero Reverse Recovery
- Temperature Independent Switching Behavior
- Positive Temperature Coefficient Device
- High Surge Current Capability
- RoHS Compliant and Halogen Free
- Optimized for High Power Application
- AEC-Q101 Qualified

Benefits

- Higher System Efficiency
- Increase Parallel Device Convenience
- Enable High Temperature Application
- Allow High Frequency Operation
- Realize Compact and Lightweight Systems
- High Reliability

Applications

- Switching Mode Power Supply
- PFC
- UPS
- Motor Drives
- Flywheel diode in Power Inverters
- Solar/Wind Renewable Energy

Circuit Diagram

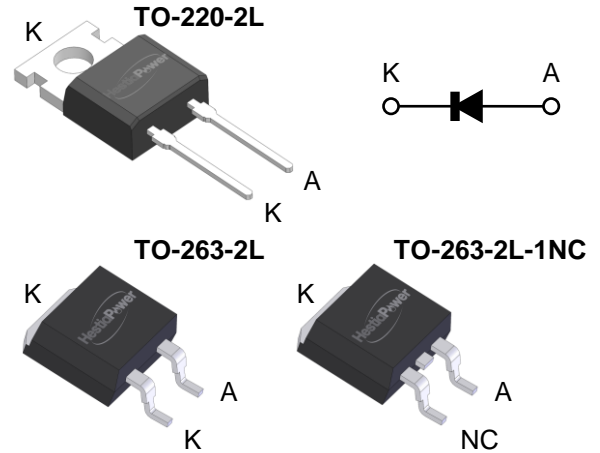

Part Number	Package	Marking
H3S120A010	TO-220-2L	H3S120A010
H3S120T010	TO-263-2L	H3S120T010
H3S120U010	TO-263-2L-1NC	H3S120U010

Absolute Maximum Ratings ($T_c = 25^\circ\text{C}$ unless otherwise specified)

Parameter	Symbol	Test Conditions	Value	Unit
Peak Repetitive Reverse Voltage	V_{RRM}	$T_J = 25^\circ\text{C}$	1200	V
Peak Reverse Surge Voltage	V_{RSM}	$T_J = 25^\circ\text{C}$	1200	V
DC Blocking Voltage	V_R	$T_J = 25^\circ\text{C}$	1200	V
Continuous Forward Current	I_F	$T_C = 25^\circ\text{C}$	32	A
		$T_C = 135^\circ\text{C}$	15	
		$T_C = 154^\circ\text{C}$	10	
Non-Repetitive Peak Forward Surge Current	I_{FSM}	$T_C = 25^\circ\text{C}$, $T_p = 10$ ms, Half Sine Wave	116	A
		$T_C = 125^\circ\text{C}$, $T_p = 10$ ms, Half Sine Wave	107	
		$T_C = 25^\circ\text{C}$, $T_p = 10$ μs , Pulse	748	
Repetitive Peak Forward Surge Current	I_{FRM}	$T_C = 25^\circ\text{C}$, $T_p = 10$ ms Half Sine Wave, $D = 0.1$	83	A
		$T_C = 125^\circ\text{C}$, $T_p = 10$ ms Half Sine Wave, $D = 0.1$	73	
Power Dissipation	P_D	$T_C = 25^\circ\text{C}$	136	W
		$T_C = 125^\circ\text{C}$	45.5	
I^2t value	$\int i^2 dt$	$T_C = 25^\circ\text{C}$, $T_p = 10$ ms	67	A^2s
Junction & Storage Temperature	T_J, T_{stg}		-55 to 175	$^\circ\text{C}$
Soldering Temperature	T_L		260	
Mounting Torque	M_D	M3 or 6-32 screw	1.0	Nm

Typical Device Performance

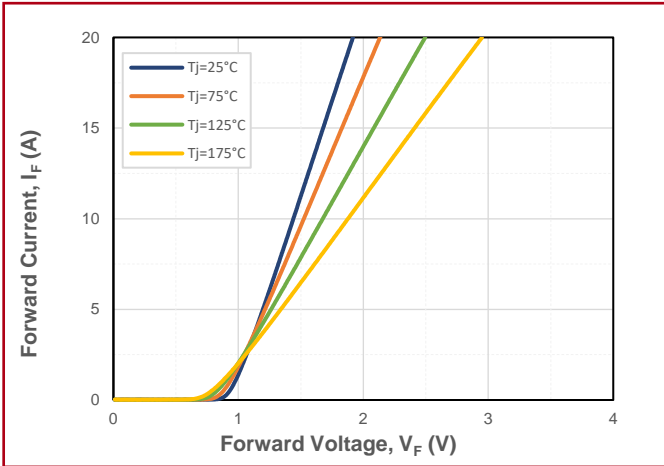

Fig.1 Forward Characteristics

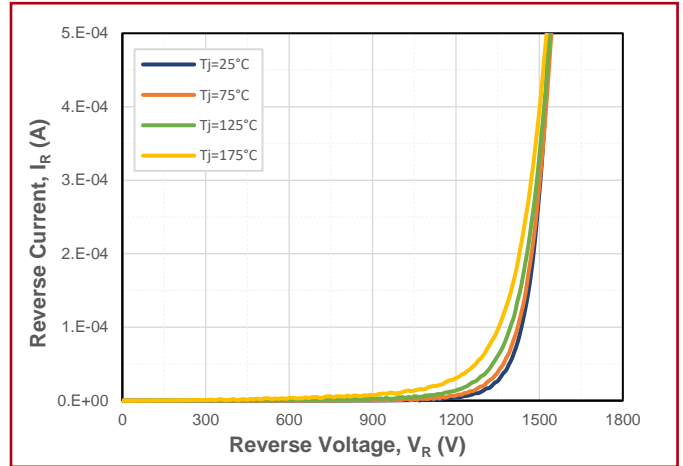

Fig.2 Reverse Characteristics

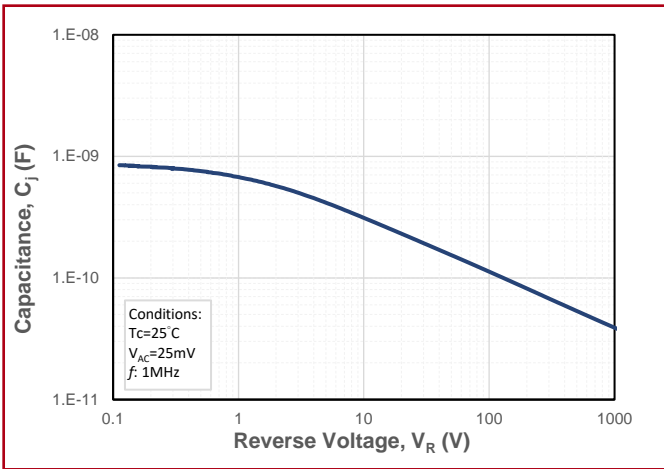

Fig.3 Junction Capacitance vs. Reverse Voltage

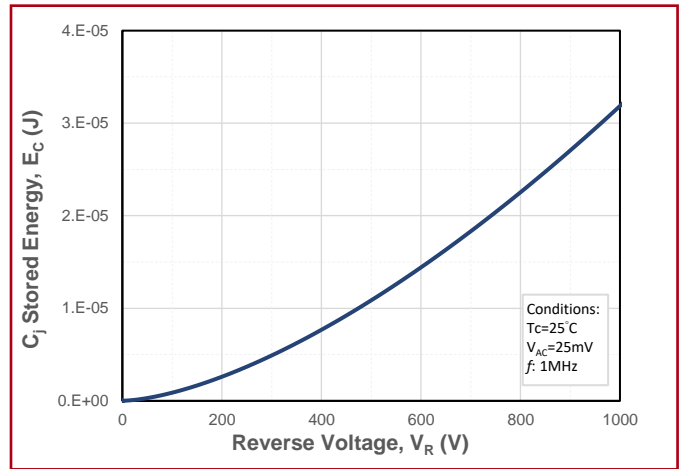

Fig.4 Capacitance Stored Energy

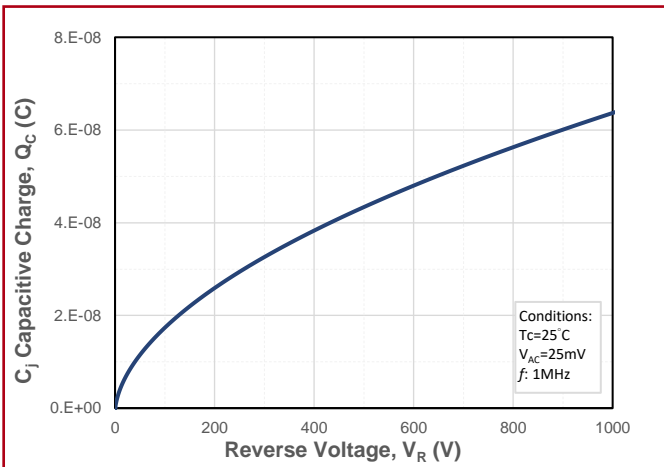

Fig.5 Recovery Charge vs. Reverse Voltage

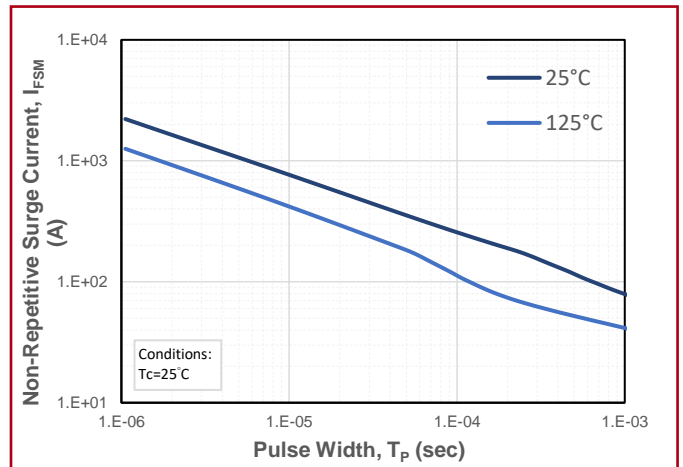

Fig.6 Non-Repetitive Peak Forward Surge Current (Pulse Mode)

Typical Device Performance

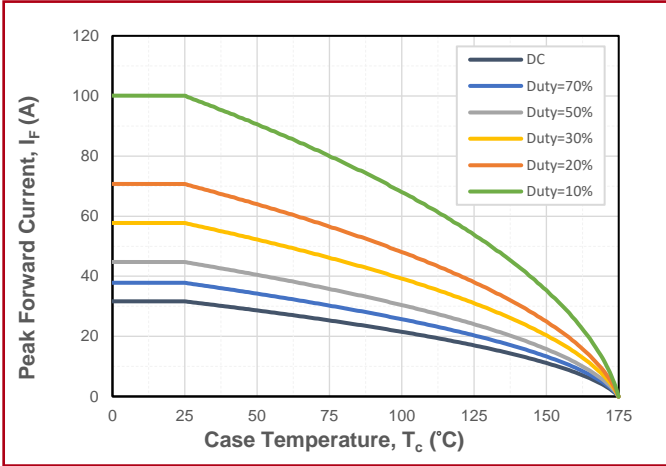

Fig.7 Maximum Forward Current Derating vs. Case Temperature

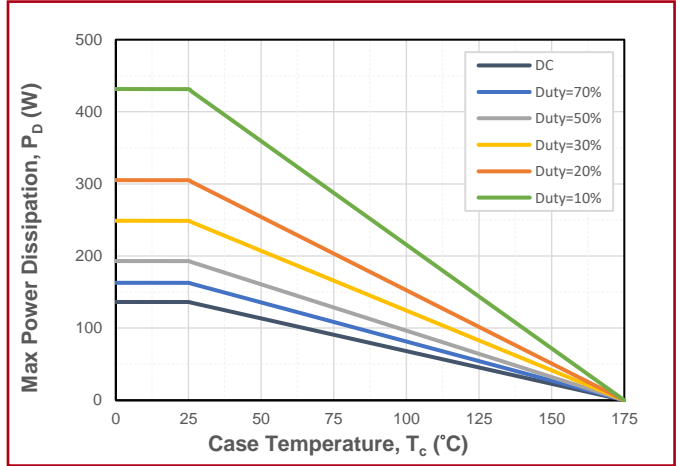

Fig.8 Maximum Power Dissipation Derating vs. Case Temperature

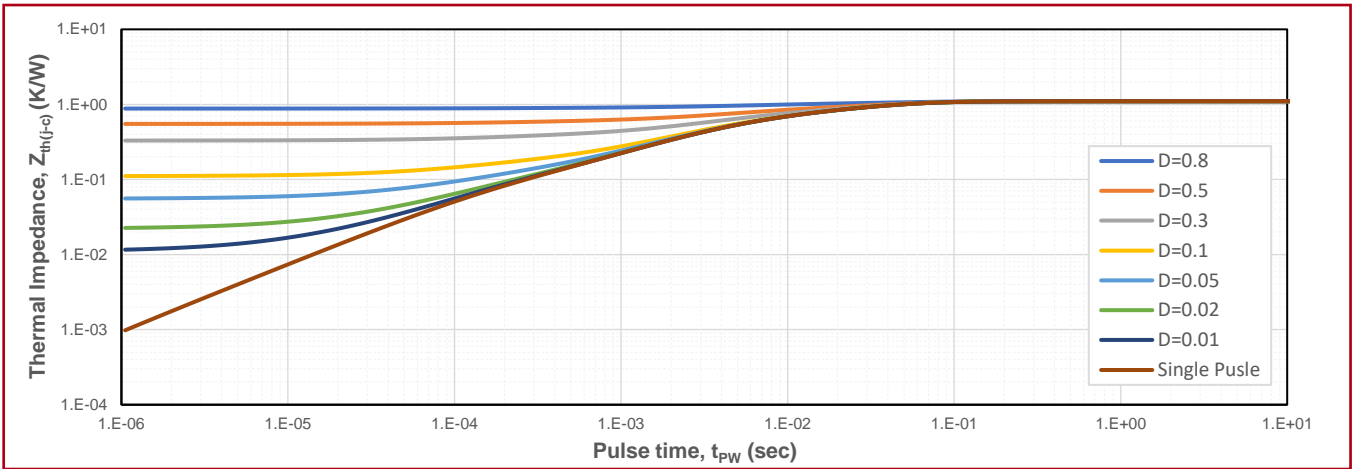
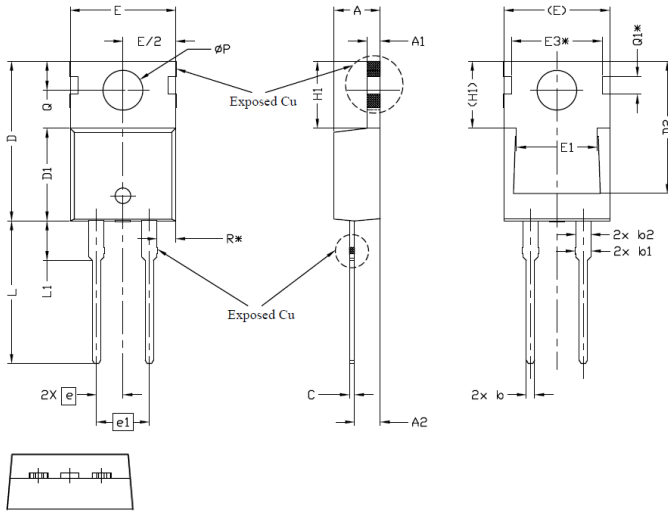

Fig.9 Transient Junction to Case Thermal Impedance

The information provided herein is subject to change without notice.

Package Dimensions (TO-220-2L)



Note:

1. Package Reference: JEDEC TO220, Variation AB.
2. All Dimensions Are In mm.
3. Slot Required, Notch May Be Rounded
4. Dimension D & E Do Not Include Mold Flash. Mold Flash Shall Not Exceed 0.127mm Pre Side. These Dimensions Are Measured At The Outermost Extreme Of The Plastic Body.
5. Thermal Pad Contour Optional Within Dimensions E, H1, D2 & E1.
6. Dimension E2 & H1 Define A Zone Where Stamping And Singulation Irregularities Are Allowed.
7. "*" is reference .

Symbol	mm		
	Min.	Typ.	Max.
A	4.24	4.44	4.64
A1	1.15	1.27	1.40
A2	2.30	2.48	2.70
b	0.70	0.80	0.90
b1	1.20	1.55	1.75
b2	1.20	1.45	1.70
c	0.40	0.50	0.60
D	14.70	15.37	16.00
D1	8.82	8.92	9.02
D2	12.63	12.73	12.83
E	9.96	10.16	10.36
E1	6.86	7.77	8.89
E3*	8.70 REF		
e	2.54 BSC		
e1	5.08 BSC		
H1	6.30	6.45	6.60
L	13.47	13.72	13.97
L1	3.60	3.80	4.00
ϕP	3.75	3.84	3.93
Q	2.60	2.80	3.00
Q1*	1.73 REF		
R*	1.82 REF		

Package Dimensions (TO-263-2L, TO-263-2L-1NC)

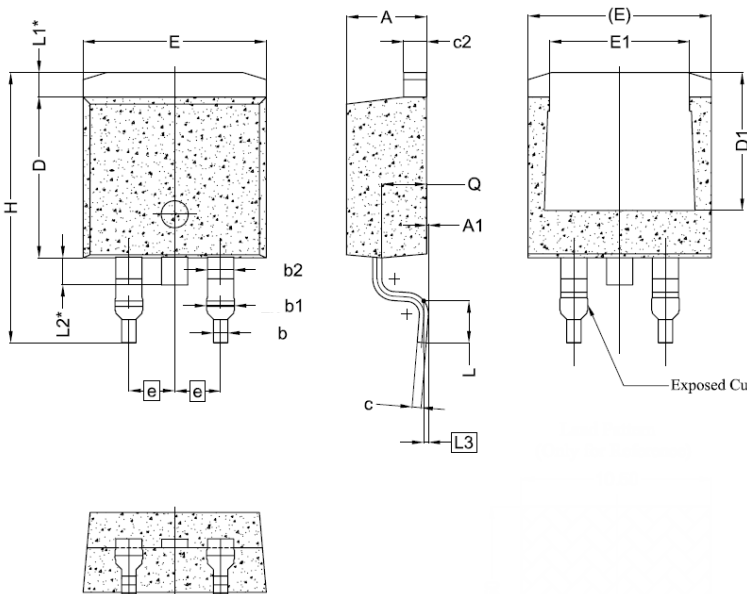

Symbol	mm		
	Min.	Typ.	Max.
A	4.24	4.44	4.64
A1	0.00	0.10	0.25
b	0.70	0.80	0.90
b1	1.20	1.55	1.75
b2	1.20	1.45	1.70
c	0.40	0.50	0.60
c2	1.15	1.27	1.40
D	8.82	8.92	9.02
D1	6.86	7.65	---
E	9.96	10.16	10.36
E1	6.89	7.77	7.89
e	2.54 BSC		
e1	5.08 BSC		
H	14.61	15.00	15.88
L	1.78	2.32	2.79
L1	1.36 REF		
L2	0.00 REF (TO-263-2L) 1.50 REF (TO-263-2L-1NC)		
L3	0.25 BSC		
Q	2.30	2.48	2.70

Note:

1. All Dimensions Are In mm.
2. Dimension D & E Do Not Include Mold Flash. Mold Flash Shall Not Exceed 0.127mm Pre Side. These Dimensions Are Measured At The Outermost Extreme Of The Plastic Body.
3. Thermal Pad Contour Optional Within Dimensions E, L1, D1 & E1.
4. Dimension D1 & E1 Establish A Minnum Mounting Surface for The Thermal Pad.
5. "*" is reference .