

## Product Summary

# H3S065X008

Part Number	Package	Marking
H3S065X008	TO-220-FP-2L	H3S065X008

$V_R$	650V
$I_{F(110/135^\circ\text{C})}$	11A/8A
$Q_C$	18.5nC



## Features

- Low Conduction and Switching Loss
- Zero Reverse Recovery
- Temperature Independent Switching Behavior
- Positive Temperature Coefficient Device
- High Surge Current Capability
- RoHS Compliant and Halogen Free
- Full Pack with Galvanic Isolation

## Benefits

- Higher System Efficiency
- Increase Parallel Device Convenience
- Enable High Temperature Application
- Allow High Frequency Operation
- Realize Compact and Lightweight Systems
- High Reliability

## Circuit Diagram

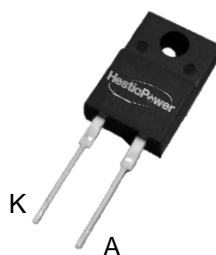

## Applications

- Switching Mode Power Supply
- PFC
- UPS
- Motor Drives
- Flywheel diode in Power Inverters
- Solar/Wind Renewable Energy

## Absolute Maximum Ratings ( $T_C = 25^\circ\text{C}$ unless otherwise specified)

Parameter	Symbol	Test Conditions	Value	Unit
Peak Repetitive Reverse Voltage	$V_{RRM}$	$I_R = 100 \mu\text{A}$	650	V
Peak Reverse Surge Voltage	$V_{RSM}$	$T_J = 25^\circ\text{C}$	650	V
DC Blocking Voltage	$V_R$	$T_J = 25^\circ\text{C}$	650	V
Continuous Forward Current	$I_F$	$T_C = 25^\circ\text{C}$	18.5	A
		$T_C = 110^\circ\text{C}$	11	
		$T_C = 135^\circ\text{C}$	8	
Non-Repetitive Peak Forward Surge Current	$I_{FSM}$	$T_C = 25^\circ\text{C}$ , $T_P = 10 \text{ ms}$ , Half Sine Wave	75	A
		$T_C = 125^\circ\text{C}$ , $T_P = 10 \text{ ms}$ , Half Sine Wave	63	
		$T_C = 25^\circ\text{C}$ , $T_P = 10 \mu\text{s}$ , Pulse	544	
Repetitive Peak Forward Surge Current	$I_{FRM}$	$T_C = 25^\circ\text{C}$ , $T_P = 10 \text{ ms}$ Half Sine Wave, $D = 0.1$	60	A
		$T_C = 125^\circ\text{C}$ , $T_P = 10 \text{ ms}$ Half Sine Wave, $D = 0.1$	49	
Power Dissipation	$P_D$	$T_C = 25^\circ\text{C}$	50	W
		$T_C = 125^\circ\text{C}$	16	
$I^2t$ value	$\int i^2 dt$	$T_C = 25^\circ\text{C}$ , $T_P = 10 \text{ ms}$	28	$\text{A}^2\text{s}$
Junction & Storage Temperature	$T_J, T_{stg}$		-55 to 175	$^\circ\text{C}$
Soldering Temperature	$T_L$		260	
Mounting Torque	$M_D$	M3 or 6-32 screw	1.0	Nm

## Electrical Characteristics (T<sub>c</sub> = 25°C unless otherwise specified)

Parameter	Symbol	Test Conditions	Min.	Typ.	Max.	Unit
DC Blocking Voltage	V <sub>DC</sub>	I <sub>R</sub> = 100 μA, T <sub>J</sub> = 25°C	> 650			V
Forward Voltage	V <sub>F</sub>	I <sub>F</sub> = 8A, T <sub>J</sub> = 25°C		1.38	1.7	V
		I <sub>F</sub> = 8A, T <sub>J</sub> = 175°C		1.59	1.9	V
Reverse Current	I <sub>R</sub>	V <sub>R</sub> = 650V, T <sub>J</sub> = 25°C		1.5	60	μA
		V <sub>R</sub> = 650V, T <sub>J</sub> = 175°C		16	240	μA
Total Capacitive Charge	Q <sub>C</sub>	I <sub>F</sub> = 8A, di/dt = 300A/μs, V <sub>R</sub> = 400V, T <sub>J</sub> = 25°C		18.5		nC
Total Capacitance	C <sub>j</sub>	V <sub>R</sub> = 1V, T <sub>J</sub> = 25°C, f = 1 MHz		403		
		V <sub>R</sub> = 200V, T <sub>J</sub> = 25°C, f = 1 MHz		53		pF
		V <sub>R</sub> = 400V, T <sub>J</sub> = 25°C, f = 1 MHz		46		
Capacitance Stored Energy	E <sub>C</sub>	V <sub>R</sub> = 400V		3.7		μJ

## Thermal Resistance

Parameter	Symbol	Min.	Typ.	Max.	Unit
Thermal Resistance, Junction to Case	R <sub>θJC</sub>		3.0		°C/W
Thermal Resistance, Junction to Ambient	R <sub>θJA</sub>				°C/W

## Naming Rule

**H3 S 065 X 008**

### Generation

H3 = Gen 3<sup>rd</sup> Discrete

### Device Type

M = MOSFET    J = JMOS    S = JBS diode

### Breakdown Voltage

065 = 650V    120 = 1200V    170 = 1700V

### Package

X = TO-220-FP-2L

### Typical Current Rating

002 = 2A    004 = 4A    006 = 6A    008 = 8A    010 = 10A    015 = 15A

## Recommended Solder Pad Layout

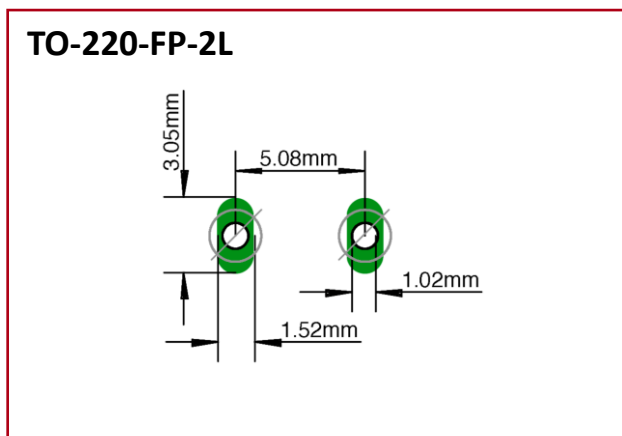

## Typical Device Performance

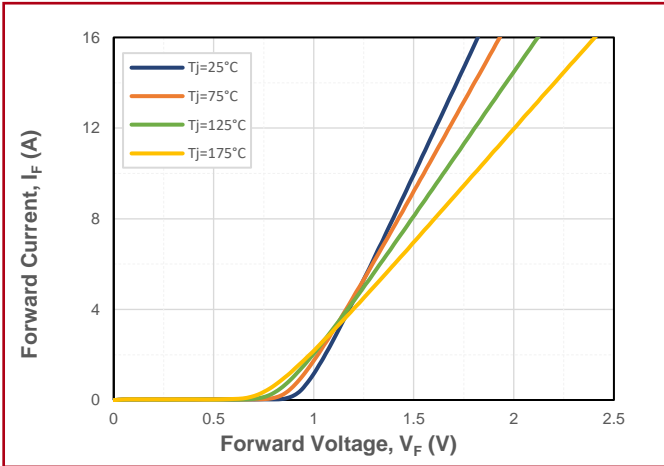

Fig.1 Forward Characteristics

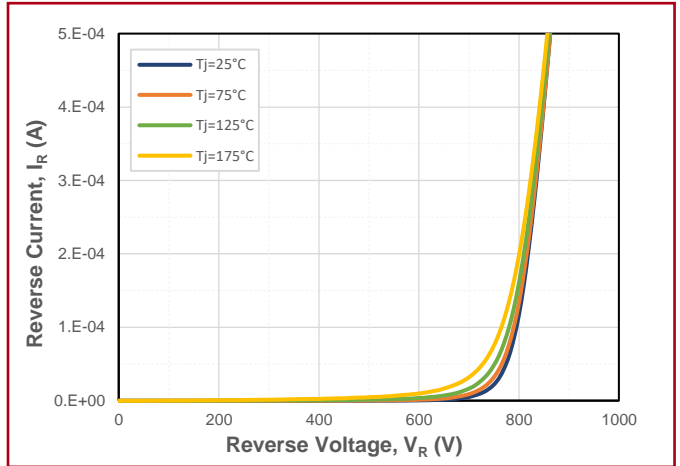

Fig.2 Reverse Characteristics

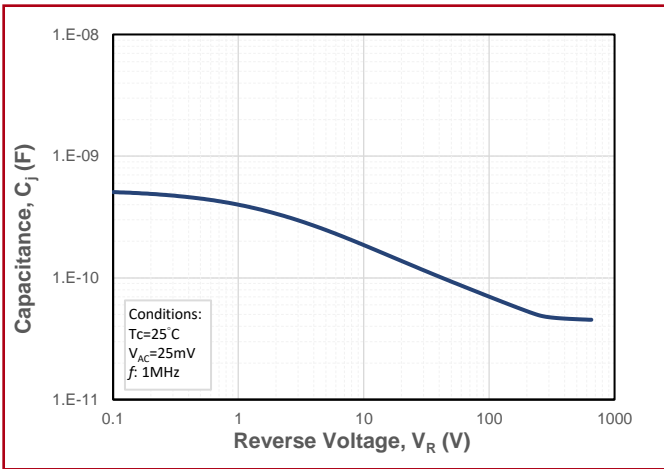

Fig.3 Junction Capacitance vs. Reverse Voltage

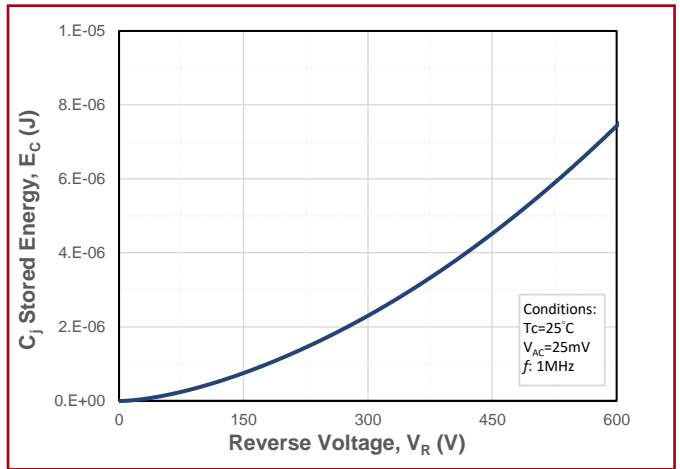

Fig.4 Capacitance Stored Energy

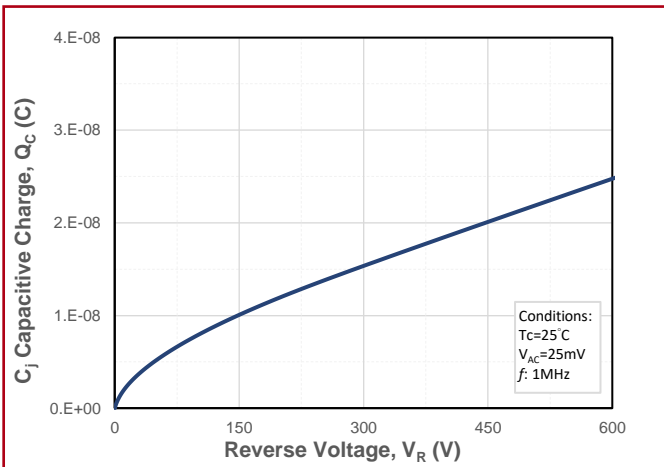

Fig.5 Recovery Charge vs. Reverse Voltage

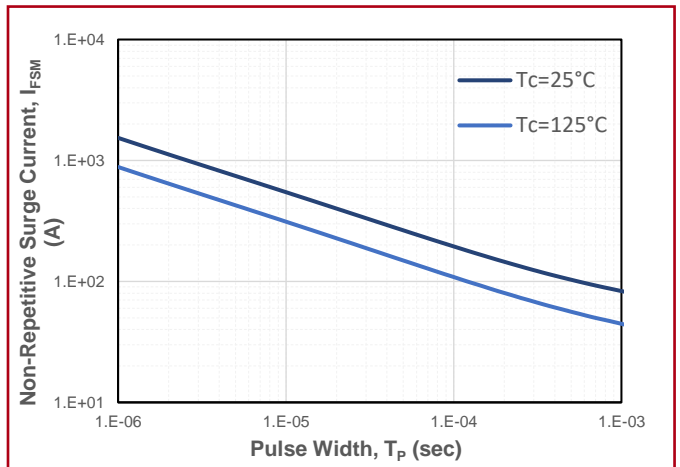
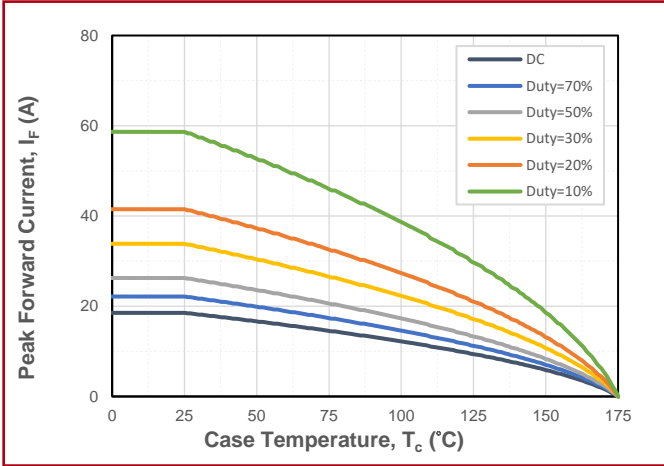
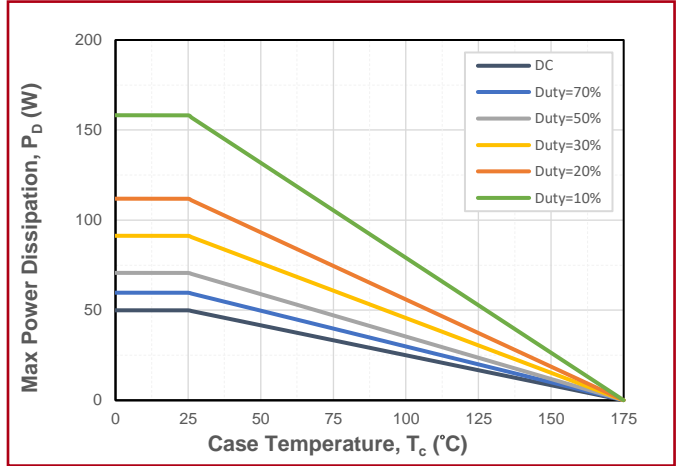

Fig.6 Non-Repetitive Peak Forward Surge Current (Pulse Mode)

### Typical Device Performance



**Fig.7 Maximum Forward Current Derating vs. Case Temperature**



**Fig.8 Maximum Power Dissipation Derating vs. Case Temperature**

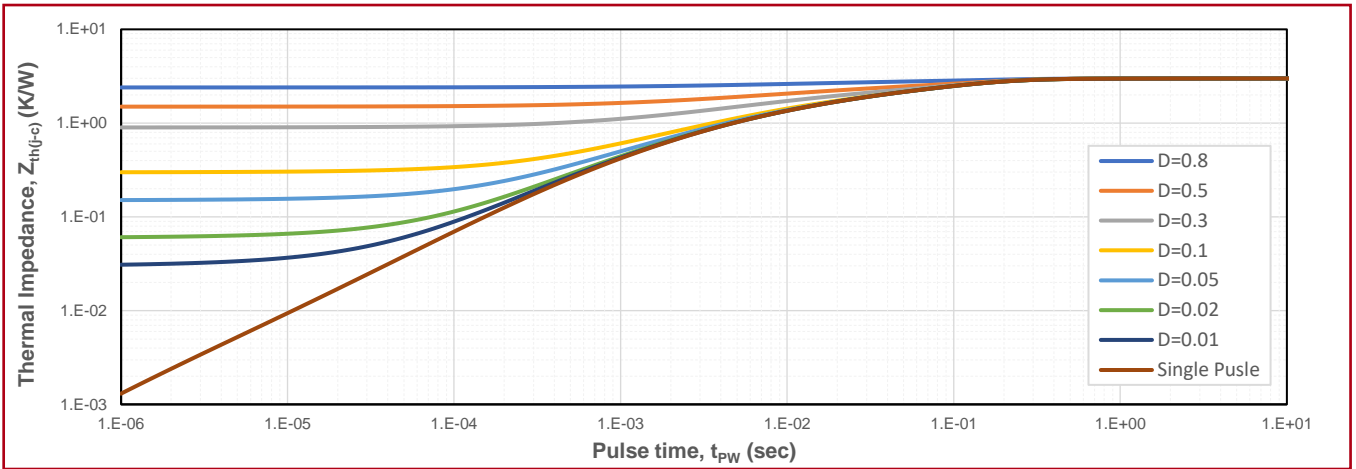

**Fig.9 Transient Junction to Case Thermal Impedance**

The information provided herein is subject to change without notice.

### Package Dimensions (TO-220-FP-2L)

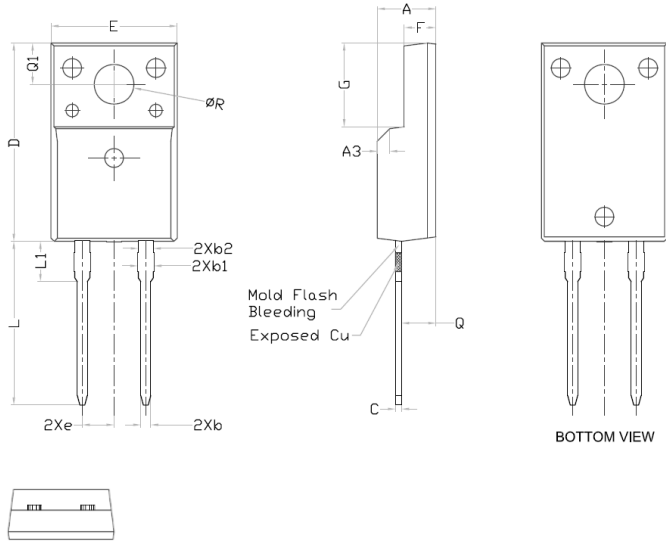

Symbol	mm		
	Min.	Typ.	Max.
A	4.60	4.70	4.80
b	0.70	0.80	0.91
b1	1.20	1.30	1.47
b2	1.10	1.20	1.30
C	0.45	0.50	0.63
D	15.80	15.87	15.97
e	2.54		
E	10.00	10.10	10.30
F	2.44	2.54	2.64
G	6.50	6.70	6.90
L	12.90	13.10	13.30
L1	3.13	3.23	3.33
Q	2.65	2.75	2.85
Q1	3.20	3.30	3.40
φR	3.08	3.18	3.28

Note:  
 1. All Dimension Are In mm.  
 2. Package Body Sizes Exclude Mold Flash And Burrs  
 Mold Flash Should Be Less Than 6 Mil.