

## Product Summary

$V_R$	650V
$I_F(135/144^\circ\text{C})$	23.6A/20A
$Q_C$	55nC



# H3S065A020, H3S065T020, H3S065U020

## Features

- Low Conduction and Switching Loss
- Zero Reverse Recovery
- Temperature Independent Switching Behavior
- Positive Temperature Coefficient Device
- High Surge Current Capability
- RoHS Compliant and Halogen Free
- Optimized for High Power Application

## Benefits

- Higher System Efficiency
- Increase Parallel Device Convenience
- Enable High Temperature Application
- Allow High Frequency Operation
- Realize Compact and Lightweight Systems
- High Reliability

## Applications

- Switching Mode Power Supply
- PFC
- UPS
- Motor Drives
- Flywheel diode in Power Inverters
- Solar/Wind Renewable Energy

## Circuit Diagram

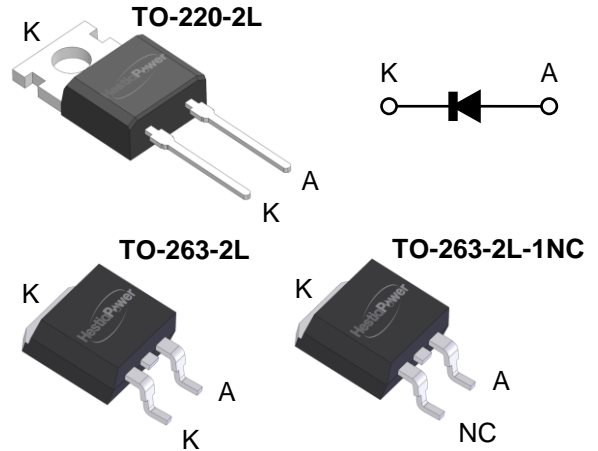

Part Number	Package	Marking
H3S065A020	TO-220-2L	H3S065A020
H3S065T020	TO-263-2L	H3S065T020
H3S065U020	TO-263-2L-1NC	H3S065U020

## Absolute Maximum Ratings ( $T_c = 25^\circ\text{C}$ unless otherwise specified)

Parameter	Symbol	Test Conditions	Value	Unit
Peak Repetitive Reverse Voltage	$V_{RRM}$	$I_R = 100 \mu\text{A}$	650	V
Peak Reverse Surge Voltage	$V_{RSM}$	$T_J = 25^\circ\text{C}$	650	V
DC Blocking Voltage	$V_R$	$T_J = 25^\circ\text{C}$	650	V
Continuous Forward Current	$I_F$	$T_C = 25^\circ\text{C}$	54	A
		$T_C = 135^\circ\text{C}$	23.6	
		$T_C = 144^\circ\text{C}$	20	
Non-Repetitive Peak Forward Surge Current	$I_{FSM}$	$T_C = 25^\circ\text{C}, T_p = 10 \text{ ms}, \text{Half Sine Wave}$	179	A
		$T_C = 125^\circ\text{C}, T_p = 10 \text{ ms}, \text{Half Sine Wave}$	157	
		$T_C = 25^\circ\text{C}, T_p = 10 \mu\text{s}, \text{Pulse}$	904	
Repetitive Peak Forward Surge Current	$I_{FRM}$	$T_C = 25^\circ\text{C}, T_p = 10 \text{ ms}$ Half Sine Wave, $D = 0.1$	117	A
		$T_C = 125^\circ\text{C}, T_p = 10 \text{ ms}$ Half Sine Wave, $D = 0.1$	110	
Power Dissipation	$P_D$	$T_C = 25^\circ\text{C}$	150	W
		$T_C = 125^\circ\text{C}$	50	
$I^2t$ value	$\int i^2 dt$	$T_C = 25^\circ\text{C}, T_p = 10 \text{ ms}$	160	$\text{A}^2\text{s}$
Junction & Storage Temperature	$T_J, T_{stg}$		-55 to 175	$^\circ\text{C}$
Soldering Temperature	$T_L$		260	
Mounting Torque	$M_D$	M3 or 6-32 screw	1.0	Nm

## Electrical Characteristics (T<sub>c</sub> = 25°C unless otherwise specified)

Parameter	Symbol	Test Conditions	Min.	Typ.	Max.	Unit
DC Blocking Voltage	V <sub>DC</sub>	I <sub>R</sub> = 100 μA, T <sub>J</sub> = 25°C	> 650			V
Forward Voltage	V <sub>F</sub>	I <sub>F</sub> = 20A, T <sub>J</sub> = 25°C		1.4	1.7	V
		I <sub>F</sub> = 20A, T <sub>J</sub> = 175°C		1.55	1.9	V
Reverse Current	I <sub>R</sub>	V <sub>R</sub> = 650V, T <sub>J</sub> = 25°C		3	150	μA
		V <sub>R</sub> = 650V, T <sub>J</sub> = 175°C		40	600	μA
Total Capacitive Charge	Q <sub>C</sub>	V <sub>R</sub> = 400V, T <sub>J</sub> = 25°C		55		nC
Total Capacitance	C <sub>j</sub>	V <sub>R</sub> = 0.1V, T <sub>J</sub> = 25°C, f = 1 MHz		1544		
		V <sub>R</sub> = 200V, T <sub>J</sub> = 25°C, f = 1 MHz		134		pF
		V <sub>R</sub> = 400V, T <sub>J</sub> = 25°C, f = 1 MHz		104		
Capacitance Stored Energy	E <sub>C</sub>	V <sub>R</sub> = 400V		11		μJ

## Thermal Resistance

Parameter	Symbol	Min.	Typ.	Max.	Unit
Thermal Resistance, Junction to Case	R <sub>θ,JC</sub>		1.0		°C/W
Thermal Resistance, Junction to Ambient	R <sub>θ,JA</sub>				°C/W

## Naming Rule

**H3 S 065 A 020**

### Generation

H3 = 3<sup>rd</sup> Gen Discrete

### Device Type

S = JBS diode (High Power)     D = JBS diode (High Speed)

### Breakdown Voltage

065 = 650V     120 = 1200V     170 = 1700V

### Package

A = TO-220-2L     T = TO-263-2L     U = TO-263-2L-1NC

### Typical Current Rating

002 = 2A     005 = 5A     008 = 8A     010 = 10A     012 = 12A     020 = 20A

## Recommended Solder Pad Layout

### TO-220-2L

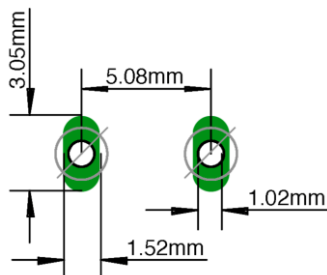

### TO-263-2L, TO-263-2L-1NC

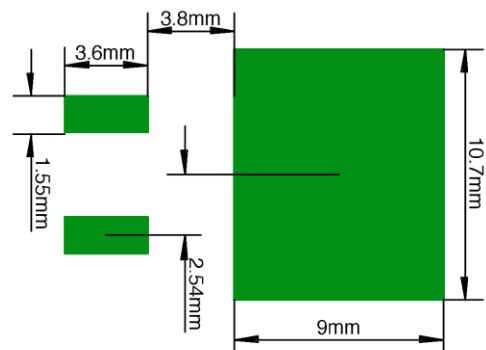

## Typical Device Performance

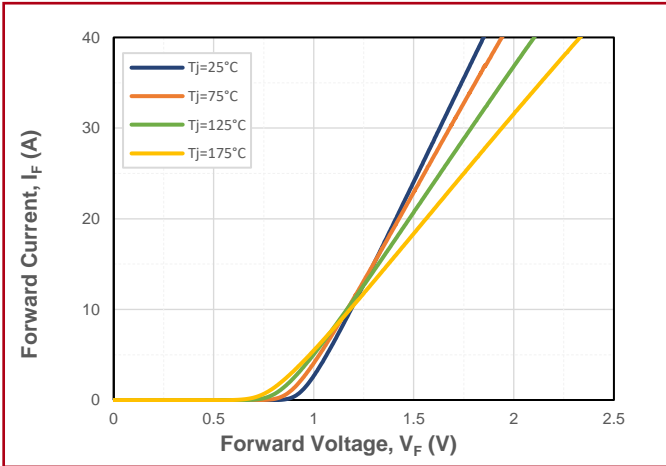

Fig.1 Forward Characteristics

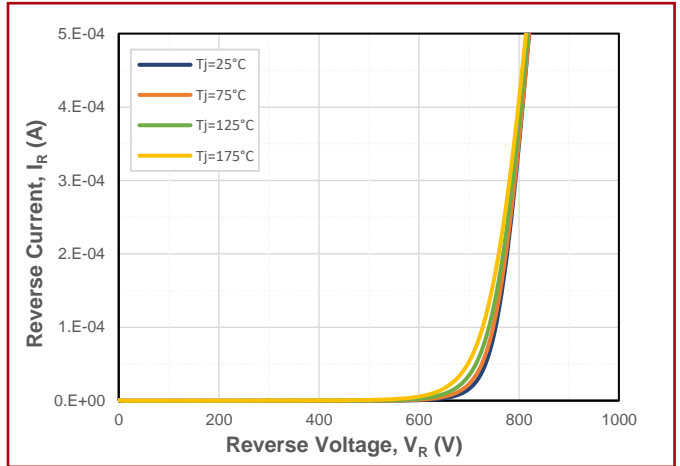

Fig.2 Reverse Characteristics

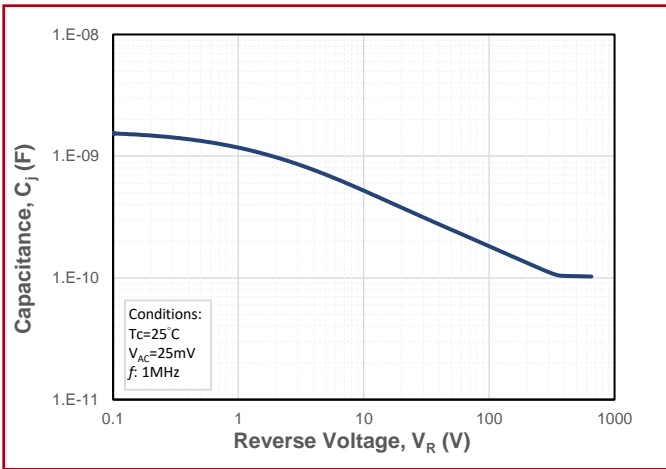

Fig.3 Junction Capacitance vs. Reverse Voltage

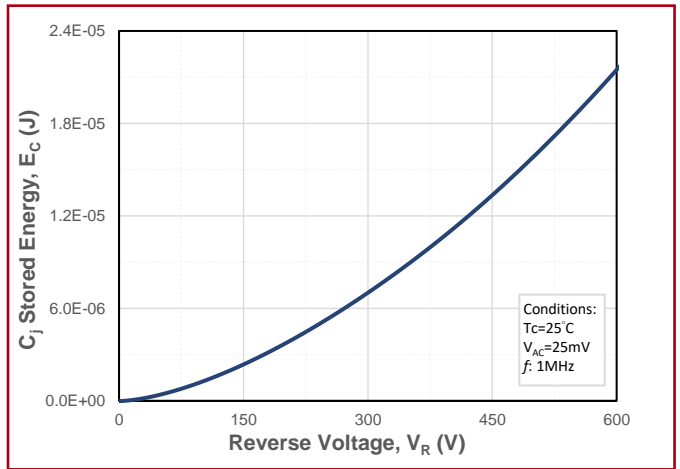

Fig.4 Capacitance Stored Energy

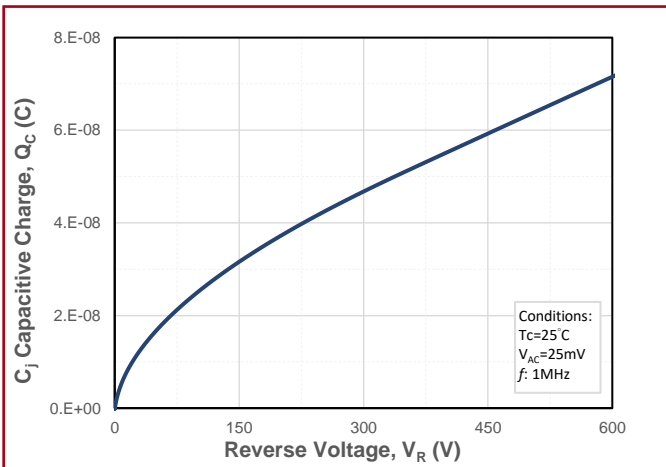

Fig.5 Recovery Charge vs. Reverse Voltage

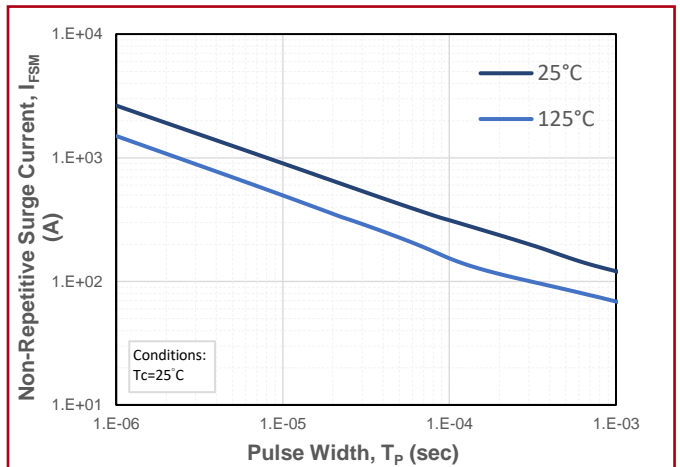
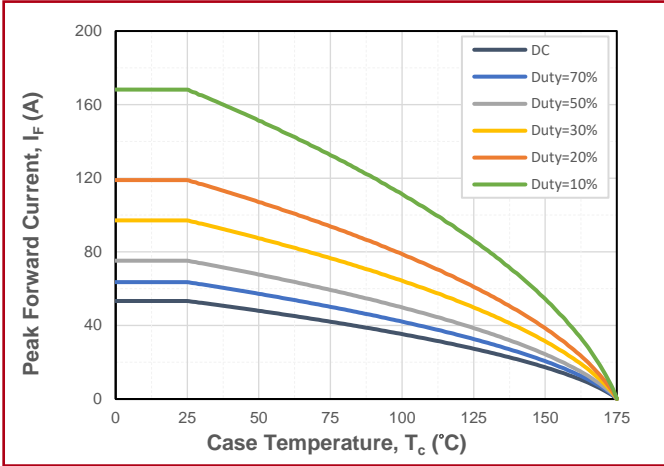
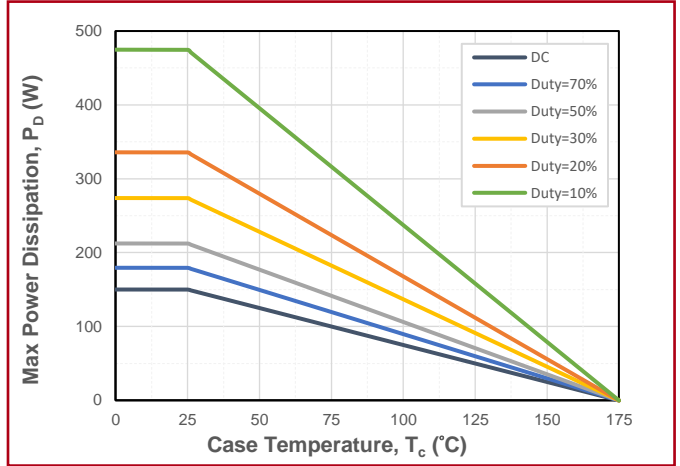

Fig.6 Non-Repetitive Peak Forward Surge Current (Pulse Mode)

### Typical Device Performance



**Fig.7 Maximum Forward Current Derating vs. Case Temperature**



**Fig.8 Maximum Power Dissipation Derating vs. Case Temperature**

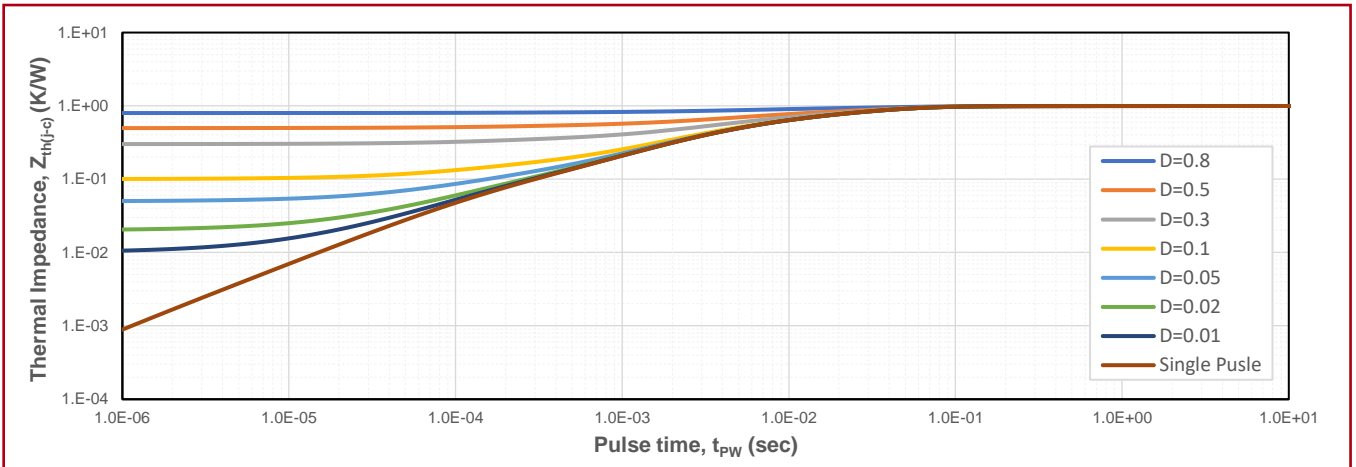

**Fig.9 Transient Junction to Case Thermal Impedance**

The information provided herein is subject to change without notice.

### Package Dimensions (TO-220-2L)

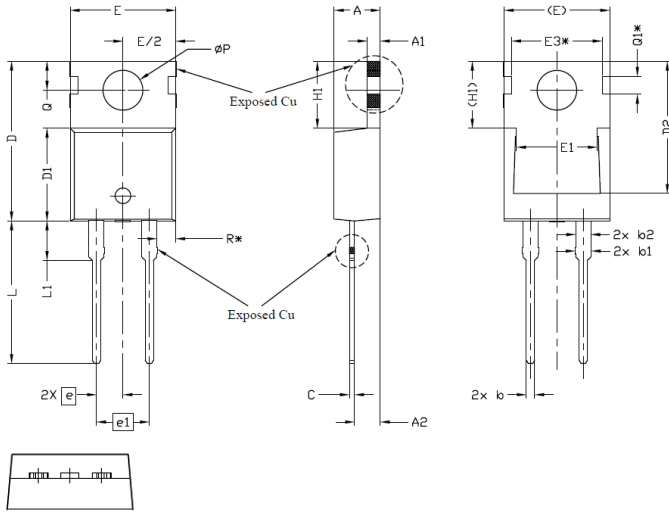

Note:

1. Package Reference: JEDEC TO220, Variation AB.
2. All Dimensions Are In mm.
3. Slot Required, Notch May Be Rounded
4. Dimension D & E Do Not Include Mold Flash. Mold Flash Shall Not Exceed 0.127mm Pre Side. These Dimensions Are Measured At The Outermost Extreme Of The Plastic Body.
5. Thermal Pad Contour Optional Within Dimensions E, H1, D2 & E1.
6. Dimension E2 & H1 Define A Zone Where Stamping And Singulation Irregularities Are Allowed.
7. "\*" is reference .

Symbol	mm		
	Min.	Typ.	Max.
A	4.24	4.44	4.64
A1	1.15	1.27	1.40
A2	2.30	2.48	2.70
b	0.70	0.80	0.90
b1	1.20	1.55	1.75
b2	1.20	1.45	1.70
c	0.40	0.50	0.60
D	14.70	15.37	16.00
D1	8.82	8.92	9.02
D2	12.63	12.73	12.83
E	9.96	10.16	10.36
E1	6.86	7.77	8.89
E3*	8.70 REF.		
e	2.54 BSC		
e1	5.08 BSC		
H1	6.30	6.45	6.60
L	13.47	13.72	13.97
L1	3.60	3.80	4.00
φP	3.75	3.84	3.93
Q	2.60	2.80	3.00
Q1*	1.73 REF.		
R*	1.82 REF.		

### Package Dimensions (TO-263-2L, TO-263-2L-1NC)

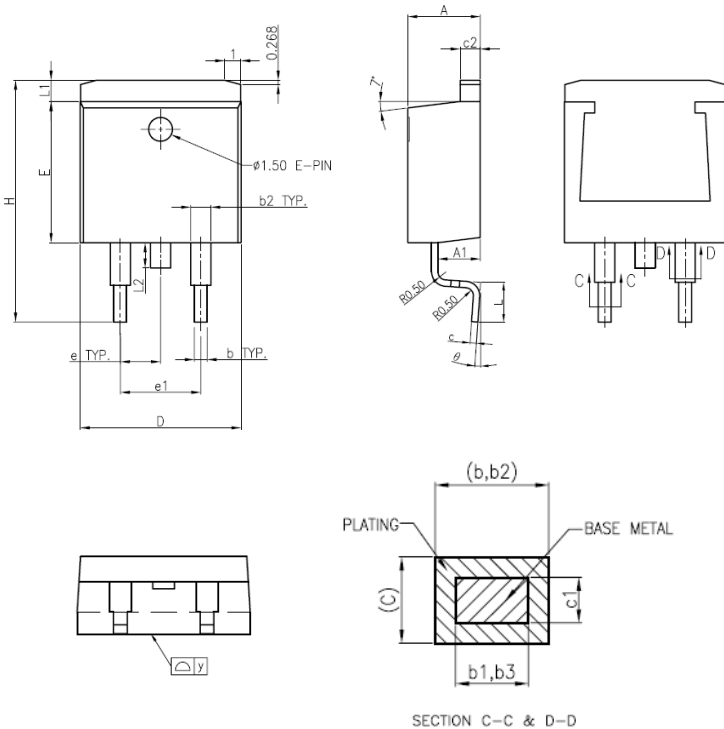

Symbol	mm		
	Min.	Typ.	Max.
A	4.47	-	4.67
A1	2.52	-	2.82
b	0.71	0.81	0.91
b1	0.71	-	0.91
b2	1.17	1.27	1.37
b3	1.17	-	1.37
c	0.279	-	0.483
c1	0.279	0.38	0.432
c2	1.17	-	1.37
D	10.01	-	10.31
E	8.76	8.89	9.02
E1	10.40	10.55	10.66
e	2.54 BSC		
e1	4.98	-	5.18
H	15.00	-	15.85
L	2.29	2.54	2.79
L1	1.27	-	1.40
L2	1.30	-	1.75
y	0	-	0.08
θ	0°	-	8°